















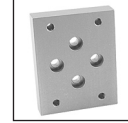





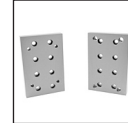







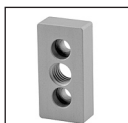





Section #8 Pictorial Table Of Contents

<p>How To Order</p>  <p>Page 458</p>	<p>Threaded Stem Swivel Casters</p>  <p>Page 459</p>	<p>Furniture Style Casters</p>  <p>Page 460</p>	<p>Flange Mount Casters</p>  <p>Page 461</p>	<p>Triangular Top Plate Casters</p>  <p>Page 462</p>	<p>Deluxe Flange Mount Casters</p>  <p>Page 463</p>	<p>Flange Mount Caster Base Plates</p>  <p>Page 464</p>
<p>Heavy-Duty Flange Mount Casters</p>  <p>Page 465</p>	<p>HD Flange Mount Caster Base Plates</p>  <p>Page 466</p>	<p>Leveling Casters</p>  <p>Page 467</p>	<p>Leveling Caster Base Plates</p>  <p>Page 468</p>	<p>Econ Position Floor Locks</p>  <p>Page 469</p>	<p>Position Floor Locks</p>  <p>Pages 470-471</p>	<p>Position Floor Lock Base Plates</p>  <p>Page 472</p>
<p>Furniture Style Glides</p>  <p>Page 473</p>	<p>Econ Furniture Style Glides</p>  <p>Page 474</p>	<p>Large Base Glides</p>  <p>Page 475</p>	<p>Mighty Mount™</p>  <p>Page 476</p>	<p>Economy Anti-Vibration Mounts</p>  <p>Page 477</p>	<p>Deluxe Leveling Feet</p>  <p>Page 478</p>	<p>Econ Leveling Feet</p>  <p>Page 479</p>
<p>10 Series Base Plates</p>  <p>Pages 480-481</p>	<p>15 Series Base Plates</p>  <p>Pages 482-483</p>	<p>10 Series Leveling Base Plates</p>  <p>Pages 484-485</p>	<p>15 Series Leveling Base Plates</p>  <p>Pages 486-487</p>	<p>Base for Swivel Feet</p>  <p>Page 488</p>	<p>Base for Swivel Feet</p>  <p>Page 488</p>	<p>Threaded Stems for Swivel Feet</p>  <p>Page 489</p>
<p>Extended Base for Swivel Feet</p>  <p>Page 490</p>	<p>Trapezoid Base for Swivel Feet</p>  <p>Page 490</p>	<p>Ball Joint 15 for Swivel Feet</p>  <p>Page 491</p>	<p>Trapezoid Base Anchor</p>  <p>Page 491</p>	<p>Wedge Floor Anchors</p>  <p>Page 492</p>	<p>Floor Brackets</p>  <p>Page 493</p>	<p>Adjustable Floor Brackets</p>  <p>Page 494</p>
<p>Floor Mount Base Plates</p>  <p>Page 495</p>	<p>Econ Floor Mount Base Plates</p>  <p>Page 496</p>					

How to Order 80/20® Floor To Frame

When selecting your method of floor to frame, follow these simple steps to make sure you have all the needed parts: decide what load capacity is required and select the appropriate part number. Check for SERIES compatibility and select compatible base plate and mounting hardware. After completing the selection process, make sure to order a profile end tap if you are mounting to a profile end. The machining service charge to tap the profile end should be included in the machining service section of your completed order.

How To Order

Shipping Method: Ship To: Customer:
 Ordered By: Address:
 City / State:
 Attention:
 Tag:

Complete Address & Shipping Method Required... NO P.O. Box

	Part Number	Quantity	Length	Description / Machining	Price/ UOM	Ext. Price
1	1010	2	18.50"	7042 in A both ends	\$.23	\$ 8.51
	1515-Lite-145	5	145.00"	Full length profile	\$65.25	\$326.25
	3060	4	40.00"	7029 one end	\$2.95	\$472.00
	3030	4	36.00"	7050 style G in W, X both ends	\$1.50	\$216.00
2	CM01-051006	2		Custom bracket per drawing #1	\$23.00	\$46.00
3	2611	1	5.25 sf.	1/4" bronze polycarb 1 @ 18" x 40" w/ 7311 per drawing	\$10.40	\$54.60
4	7150	1		Cut plastic panels all sides < -48"	\$10.50	\$10.50
	7042	4		10 Series anchor fastener counterbore	\$2.25	\$9.00
	7005	2		Cut-to-length for 1010	\$1.95	\$3.90
	7023	4		Cut-to-length for 3060	\$2.90	\$11.60
	7030	4		Cut-to-length for 3030	\$2.60	\$10.40
	7050	64		15 Series drill access hole	\$1.95	\$124.80
	7029	4		5/16-18 tap service for 3060	\$15.20	\$60.80
	7311	2		Anchor fastener notch for 10 Series	\$0.53	\$1.06
5	3380	32		15 Series 5/16-18 black zinc end fastener w/ screw	\$1.60	\$51.20
	2114	16		Gray T-Slot covers for 10 Series	\$3.45	\$55.20
	2050	8		End caps for 3030	\$1.85	\$14.80
	3395	4		10 Series anchor fasteners	\$2.90	\$11.60
	3279	5		15 Series 5/16-18 black zinc double economy T-nut	\$0.79	\$3.95
	4132	12		2 hole inside corner gusset bracket	\$3.95	\$47.40
	3393	24		10 Series 1/4-20 BHSCS & economy T-nut	\$0.40	\$9.60
TOTAL					\$309.81	\$1549.17

NOTE: Prices shown for illustration use only. Contact your distributor for a personalized quote.

Special Instructions: **Must be delivered for assembly by Friday!!!**

- 1 - Profiles = Pages 147-202 • 2 - Custom Parts = Pages 203-220 • 3 - Panels = Pages 349-432
- 4 - Machining Services = Pages 559-608 • 5 - Accessories & Tools = Pages 433-456 & 549-558

Threaded Stem Swivel Casters
Zinc-Plated Steel Bracket w/Black Nylon Wheel



- 10 and 15 Series compatible
- Mounts directly to profile ends (with end tap) or to mounted base plates
- Maximum load capacity ratings from 70-200 lbs.
- Brake kits are included with select casters
- Oil resistant
- Refer to pages 480-483 for base plate options and page 564 for profile end tap services

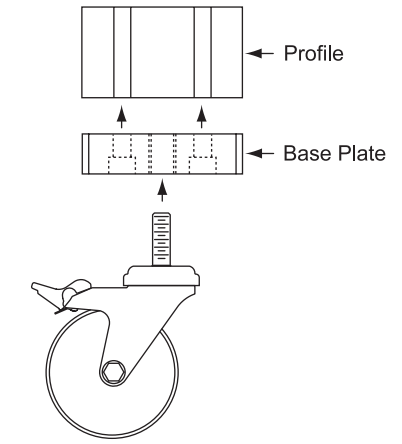
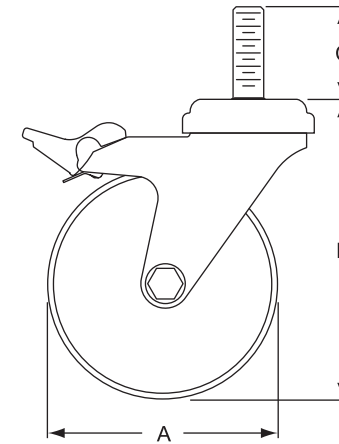

Part No.	Thread	A	B	C	Brake	Swivel Radius	Max Load Lbs. (Kg)	Lbs. (Kg)
2298	3/8-16	1.625	2.313	1.5	No	1.625	70.00 (31.75)	0.29 (.130)
2299	3/8-16	2.000	2.625		1.812	75.00 (34.02)	0.35 (.159)	
2300	3/8-16	3.000	3.625	1.5	Yes	2.375	100.00 (45.36)	0.55 (.248)
2310	7/16-14	4.000	4.625			3.187	125.00 (56.70)	1.21 (.547)
2305	7/16-14	4.000	4.625			3.187	125.00 (56.70)	1.25 (.567)
2306	7/16-14	5.000	5.625			3.687	200.00 (90.72)	1.28 (.580)
2307	7/16-14	5.000	5.625			3.687	200.00 (90.72)	1.80 (.816)

Legend for Icons

This part is 10 Series compatible

Design files for this part can be found on the 80/20® DVD (Design Software)

This part can use double economy T-nuts (see bolt kit table P on page 268)

This part can use triple economy T-nuts (see bolt kit table Q on page 268)

Furniture Style Casters



- 10 and 15 Series compatible
- Available with or without brakes
- Maximum load capacity ratings range from 165-265 lbs.
- Refer to pages 480-483 for base plate options
- See page 564 for tapping services

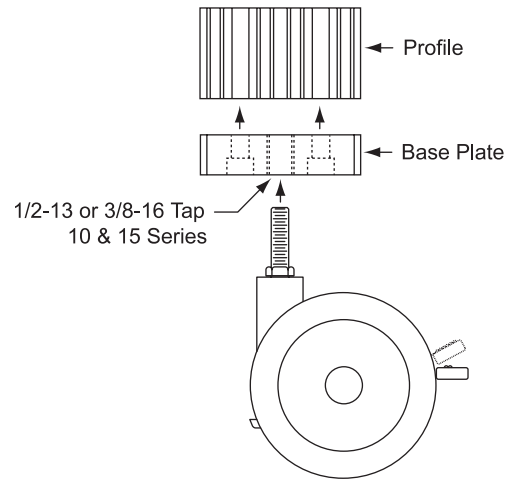
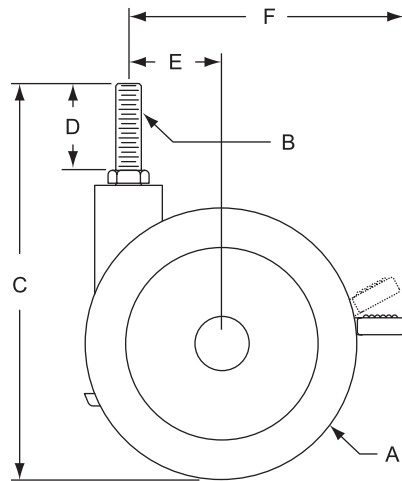

Part No.	Diameter	A	B	C	D	E	F	Capacity	Load Height	Wheel Color	Brake	Lbs.
2291	3.000	2.850	3/8-16	4.210	1.000"	.944	-	165 Lbs.	3.210	Black	No	.570
2292	3.000	2.850	3/8-16	4.210	1.000"	.944	3.660	165 Lbs.	3.210	Black	Yes	.570
2293	4.000	3.930	3/8-16	5.330	1.000"	1.370	-	225 Lbs.	4.330	Black	No	.827
2294	4.000	3.930	3/8-16	5.330	1.000"	1.370	4.880	225 Lbs.	4.330	Black	Yes	.827
2295	5.000	4.920	1/2-13	6.410	1.000"	1.370	-	265 Lbs.	5.410	Black	No	1.312
2296	5.000	4.920	1/2-13	6.410	1.000"	1.370	5.750	265 Lbs.	5.410	Black	Yes	1.312

Flange Mount Casters



- 10 and 15 Series compatible
- Choose from rigid or swivel casters, with brake kits on all swivel casters
- Side brake (pictured left) locks wheel only
- Front brake locks wheel and swivel motion
- Maximum load capacity ratings range from 150-280 lbs.
- Refer to page 464 for base plate options

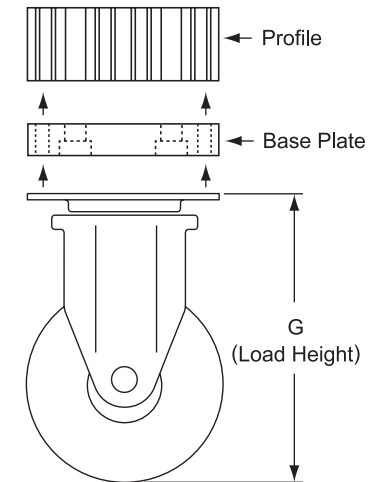
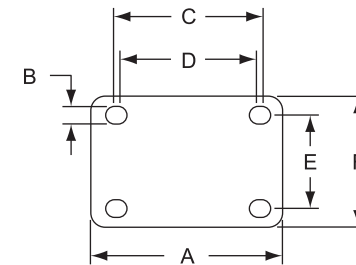

Recommended Mounting Hardware (Caster to Base Plate):

Part Number	Qty	Description
3110	4	5/16-18 x 5/8" SHCS

Swivel Caster Part No.	Diameter	A	B	C	D	E	F	G	Oil Resistance	Capacity	Wheel Color	Brake	Swivel Radius	Lbs.
2317*	3.000	3.630	.328	2.950	2.687	1.750	2.375	3.750	Average	150 Lbs.	Black	Side	2.687	1,500
2318**	3.000	3.630	.328	2.950	2.687	1.750	2.375	3.750	Average	220 Lbs.	Black	Side	2.687	1,500
2321***	4.000	3.630	.328	2.950	2.687	1.750	2.375	5.130	Good	255 Lbs.	Gray	Front	3.500	2,500
2323***	5.000	3.630	.328	2.950	2.687	1.750	2.375	6.218	Good	280 Lbs.	Gray	Front	4.000	3,000

Rigid Caster Part No.	Diameter	A	B	C	D	E	F	G	Oil Resistance	Capacity	Wheel Color	Brake	Lbs.
2311*	3.000	3.630	.328	2.950	2.687	1.750	2.375	3.750	Average	150 Lbs.	Black	No	1,500
2312**	3.000	3.630	.328	2.950	2.687	1.750	2.375	3.750	Average	220 Lbs.	Black	No	1,500
2314***	4.000	3.630	.328	2.950	2.687	1.750	2.375	5.130	Good	255 Lbs.	Gray	No	2,000
2316***	5.000	3.630	.328	2.950	2.687	1.750	2.375	6.218	Good	280 Lbs.	Gray	No	2,500

* Wheel Material: Soft Rubber
 ** Wheel Material: Hard Rubber
 *** Wheel Material: Thermoplastic Elastomer on Plastic Core

Triangular Top Plate Casters



- 15 Series compatible
- Mounts directly onto T-slotted profiles without base plates
- Wheel and swivel rotation stop when locking tab is depressed
- Maximum load capacities of 250 and 275 lbs.

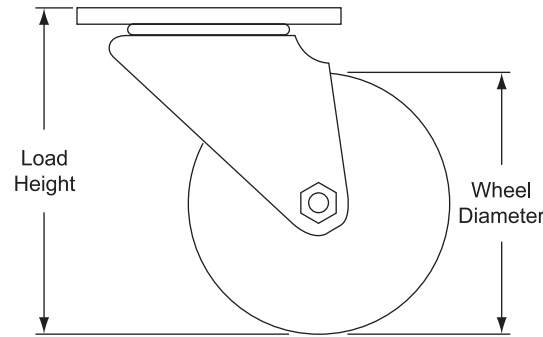
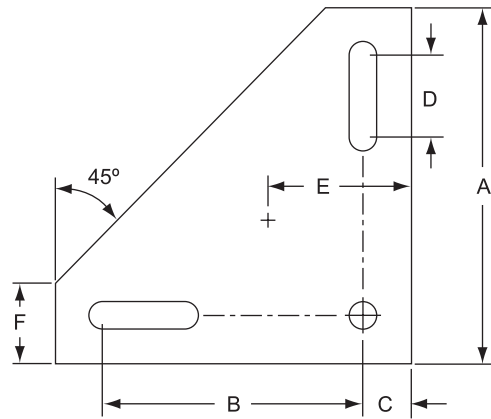

Recommended Mounting Hardware (Caster to T-Slot):

Part Number	Qty	Description
3462	3	5/16-18 x 5/8" SHCS, Washer & Econ T-Nut

Part No.	Diameter	A	B	C	D	E	F	Load Height	Capacity	Swivel Radius	Wheel Color	Lbs.
2337	4.000	5.500	4.125	.750	1.250	2.125	1.125	5.560	250 Lbs.	3.000	Gray	2.866
2338	5.000	5.500	4.125	.750	1.250	2.125	1.125	6.560	275 Lbs.	3.625	Gray	3.347

Deluxe Flange Mount Casters



- 10 and 15 Series compatible
- All casters have polyurethane wheels and hardened raceways for smooth motion
- Press brake to lock swivel and wheel, press again to unlock
- 250 - 265 lbs. load capacity range
- Use caster mount base plates on page 464 for mounting to T-slot profiles

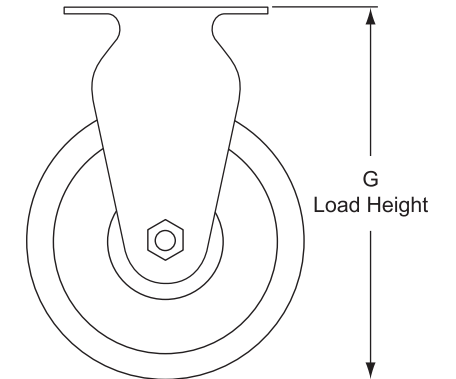
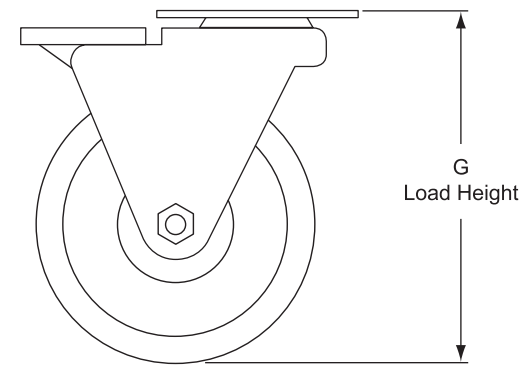
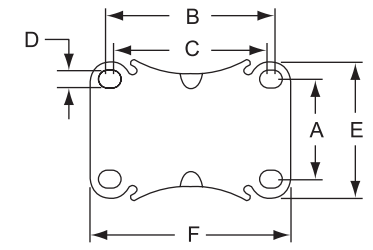
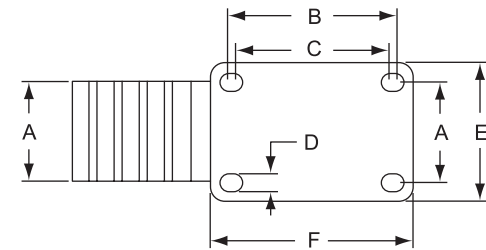

Recommended Mounting Hardware (Caster to Base Plate):

Part Number	Qty	Description
3110	4	5/16-18 x 5/8" SHCS

Swivel Caster Part No.	Diameter	A	B	C	D	E	F	G	Swivel Radius	Oil Resistance	Capacity	Wheel Color	Brake	Lbs.
2333*	4.000	1.750	2.950	2.687	.340	2.375	3.630	5.125	4.625	Very Good	250 Lbs.	Blk / Gray	Yes*	2.500
2334*	5.000	1.750	2.950	2.687	.340	2.375	3.630	6.218	4.625	Very Good	265 Lbs.	Blk / Gray	Yes*	3.250

Rigid Caster Part No.	Diameter	A	B	C	D	E	F	G	Swivel Radius	Oil Resistance	Capacity	Wheel Color	Brake	Lbs.
2335*	4.000	1.750	2.950	2.687	.340	2.375	3.630	5.125	—	Very Good	250 Lbs.	Blk / Gray	No	2.125
2336*	5.000	1.750	2.950	2.687	.340	2.375	3.630	6.218	—	Very Good	265 Lbs.	Blk / Gray	No	2.625

* Wheel Material: Polyurethane Tread Plastic Core

Flange Mount Caster Base Plates



- 10 and 15 Series compatible
- Bolts to profile end or T-slot
- Made of 6105-T5 clear anodized aluminum
- Mounts casters on pages 461 and 463

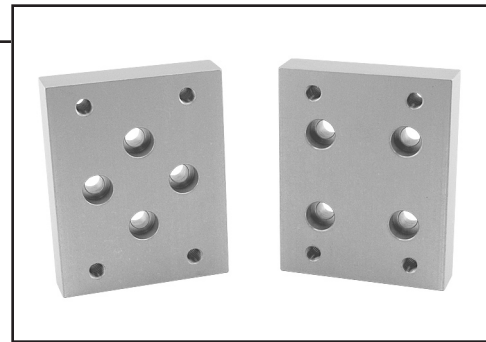

Part No: ☒ 2418 and 2420

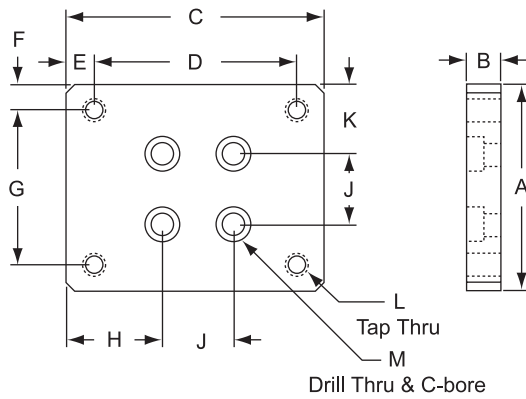

Part No: ☒ 2419 and 2426

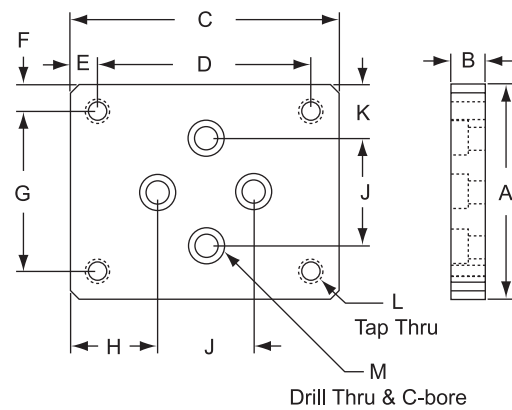

Part No.	A	B	C	D	E	F	G	H	J	K	L	M	Lbs.
2418 ☒	2.500	.500	3.750	2.940	.405	.375	1.750	1.375	1.000	.750	5/16-18	1/4-20 SHCS	.430
2419 ☒	2.500	.500	3.750	2.940	.405	.375	1.750	1.375	1.000	.750	5/16-18	1/4-20 SHCS	.430
2426	3.000	.750	3.750	2.940	.405	.625	1.750	1.125	1.500	.750	5/16-18	5/16-18 SHCS	.755
2420	3.000	.750	3.750	2.940	.405	.625	1.750	1.125	1.500	.750	5/16-18	5/16-18 SHCS	.755

☒ = 10 Series Compatible Part

Recommended Mounting Hardware (Mount to T-Slot):

Part No.	Qty	Description
3491 ☒	4	1/4-20 x 1/2" SHCS & Economy T-Nut
3458	4	5/16-18 x 7/8" SHCS & Economy T-Nut

Recommended Mounting Hardware (Mount to Profile End):

Part No.	Qty	Description
3064 ☒	4	1/4-20 x 3/4" SHCS
3123	4	5/16-18 x 1 1/4" SHCS

Heavy-Duty Flange Mount Caster



- 15 Series compatible
- Choose from swivel or rigid with load capacities ranging from 500-900 lbs.
- Available in 5" or 6" wheel diameters – no brakes
- Design allows for easy access to lubrication fittings
- Use caster mount base plates on page 466 for mounting to T-slots

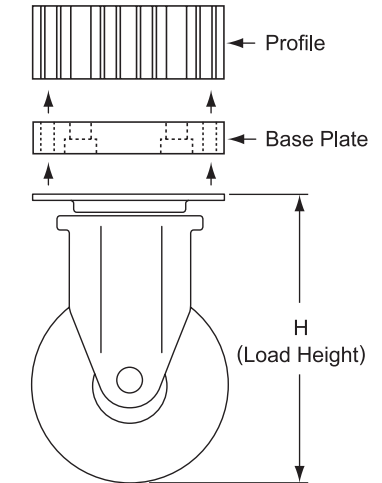
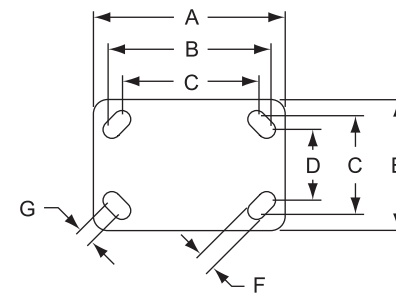

Recommended Mounting Hardware (Caster to Base Plate):

Part Number	Qty	Description
3125	4	3/8-16 x 3/4" SHCS

Swivel Caster Part No.	Diameter	A	B	C	D	E	F	G	H	Swivel Radius	Oil Resistance	Capacity	Wheel Color	Lbs.
2700*	5.000	4.500	3.620	3.000	2.620	4.000	.420	.562	6.500	4.250	Average	500 Lbs.	Gray	4.630
2704*	6.000	4.500	3.620	3.000	2.620	4.000	.420	.562	7.500	5.000	Average	550 Lbs.	Gray	5.000
2708**	5.000	4.500	3.620	3.000	2.620	4.000	.420	.562	6.500	4.250	Good	800 Lbs.	Dark Red	5.100
2712**	6.000	4.500	3.620	3.000	2.620	4.000	.420	.562	7.500	5.000	Good	900 Lbs.	Dark Red	5.850

Rigid Caster Part No.	Diameter	A	B	C	D	E	F	G	H	Swivel Radius	Oil Resistance	Capacity	Wheel Color	Lbs.
2701*	5.000	4.500	3.620	3.000	2.620	4.000	.420	.562	6.500	—	Average	500 Lbs.	Gray	3.800
2705*	6.000	4.500	3.620	3.000	2.620	4.000	.420	.562	7.500	—	Average	550 Lbs.	Gray	4.230
2709**	5.000	4.500	3.620	3.000	2.620	4.000	.420	.562	6.500	—	Good	800 Lbs.	Dark Red	4.280
2713**	6.000	4.500	3.620	3.000	2.620	4.000	.420	.562	7.500	—	Good	900 Lbs.	Dark Red	5.040

* Wheel Material: Thermoplastic Elastomer on Plastic Core

** Wheel Material: Polyurethane Tread Plastic Core

Heavy-Duty Flange Mount Caster Base Plate

- 15 Series compatible
- Mounts heavy-duty casters on page 465 to the profile end or T-slot
- Made of 6105-T5 clear anodized aluminum
- Also serves as a heavy-duty joining plate

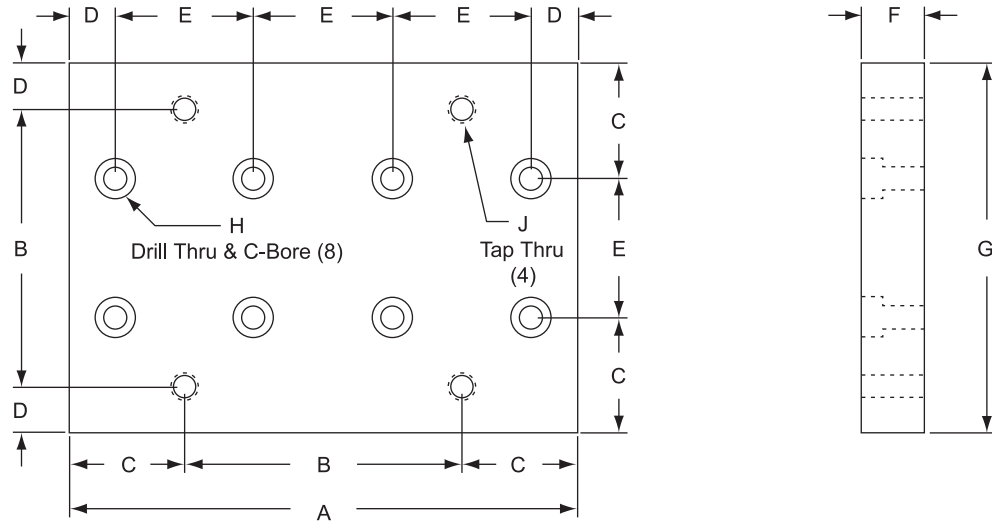
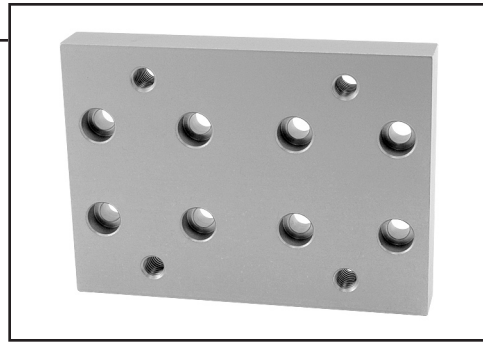

Recommended Mounting Hardware (Mount to T-Slot):

Part No.	Qty	Description
3458	4 To 8	5/16-18 x 7/8" SHCS & Economy T-Nut

Recommended Mounting Hardware (Mount to Profile End):

Part No.	Qty	Description
3123	2 To 4	5/16-18 x 1 1/4" SHCS

Part No.	A	B	C	D	E	F	G	H	J	Lbs.
2147	5.500	3.000	1.250	.500	1.500	.750	4.000	5/16-18 SHCS	3/8-16	1.505

Leveling Casters



- 10 and 15 Series compatible
- Move and level your frame with one component
- Available in four sizes with load capacity ranging from 300-1300 lbs.
- Base plates required for mounting to T-slotted profiles – see page 468

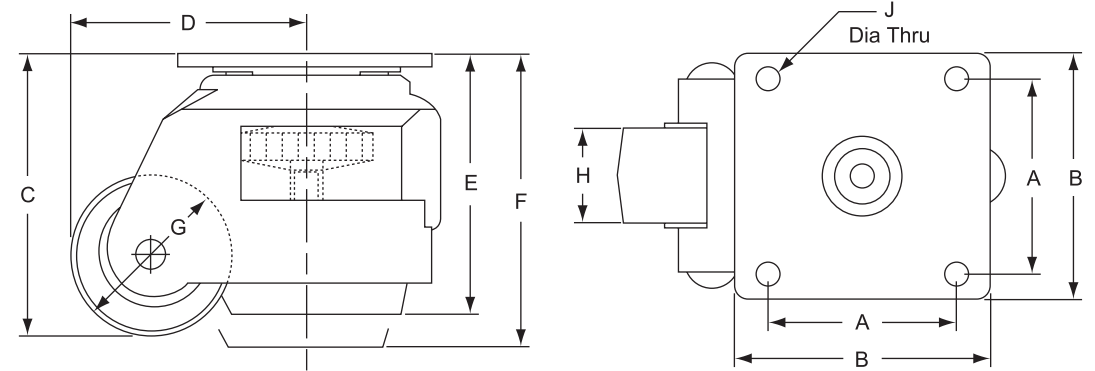

Recommended Mounting Hardware (Caster To Base Plate):

Caster No.	Base Plate	Bolt Kit	Quantity
2714	2406 ☒ / 2407	3064	4
2715	2408	3112	4
2716	2409	3125	4
2717			

☒ = 10 Series Compatible Part

Part No.	Capacity	A	B	C	D	E	F	G	H	J	Lbs.
2714	300 Lbs.	2.280	2.870	3.300	2.370	2.750	3.500	1.970	.860	.250	1.710
2715	600 Lbs.	2.750	3.540	4.020	3.030	3.625	4.625	2.440	1.140	.312	2.920
2716	1000 Lbs.	2.750	3.740	4.720	3.640	4.125	5.375	2.840	1.220	.375	3.990
2717	1300 Lbs.	2.750	3.740	4.720	3.640	4.250	4.875	2.840	1.220	.375	7.870

Leveling Caster Base Plates



- 10 and 15 Series compatible
- Mounts leveling casters shown on page 467 to the profile end or T-slot
- Made of 6105-T5 clear anodized aluminum
- Four sizes available

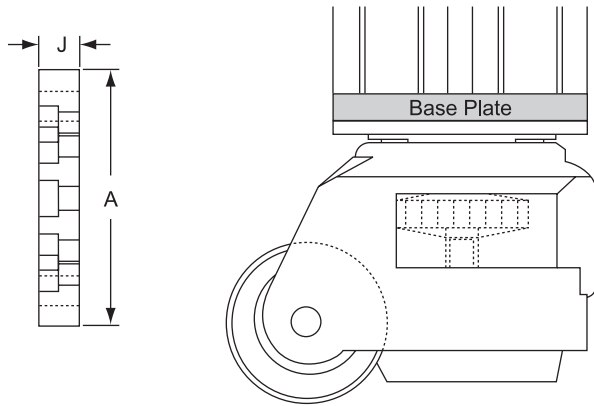
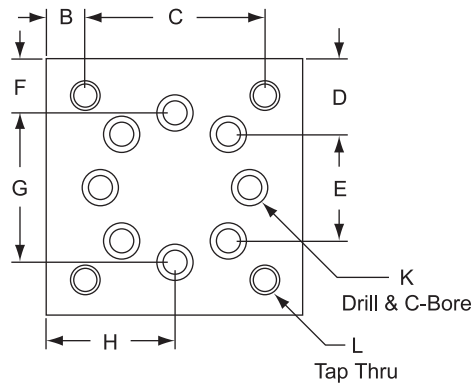
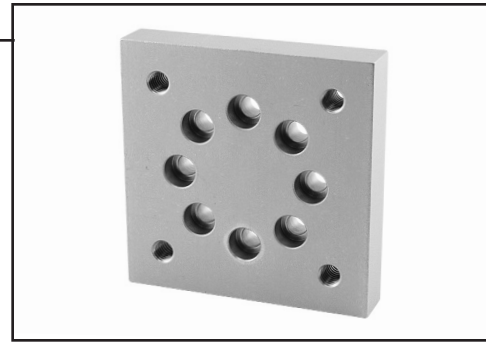

Recommended Mounting Hardware (Mount to T-Slot):

Plate No.	Bolt Kit	Quantity
2406 ☒	3491 ☒	4
2407	3458	4
2408		
2409		

Recommended Mounting Hardware (Mount to Profile End):

Plate No.	Bolt Kit	Quantity
2406 ☒	3064 ☒	4
2407	3123	4
2408		
2409		

Part No.	A	B	C	D	E	F	G	H	J	K	L	Lbs.
2406 ☒	3.000	.358	2.280	1.000	1.000	.793	1.410	1.500	.500	1/4 SHCS	1/4-20	.390
2407	3.000	.358	2.280	1.000	1.500	.439	2.120	1.500	.750	5/16 SHCS	1/4-20	.570
2408	3.500	.372	2.750	.750	1.500	.689	2.120	1.750	.750	5/16 SHCS	5/16-18	.796
2409	4.000	.622	2.750	1.250	1.500	.939	2.120	2.000	.750	5/16 SHCS	3/8-16	1.060

☒ = 10 Series Compatible Part

Economy Position Floor Locks

- 15 Series compatible
- Can be mounted to the profile T-slot or end by using base plates – see page 472
- Immobilize equipment with 90-120 lbs. force per lock through spring-loaded rubber foot pad
- Double pedals for safer options
- When properly applied, frame will not lift off floor

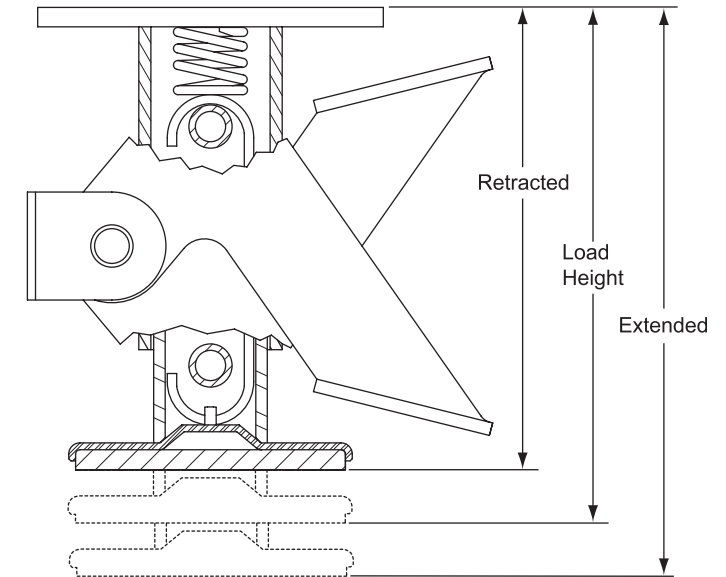

Recommended Mounting Hardware (Floor Lock to Base Plate):

Bolt Kit	Quantity	Description
3289	4	3/8-16 x 1" SHCS & Washer

Part No.	Base Plate Part No.	Retracted	Load Height	Extended	Bolt Hole Spacing	Bolt Diameter	Finish	Lbs.
2723	2148	6.000	6.625	6.875	2.630 x 3.630	3/8-16	Electro-Plated	4.750
2724	2148	6.875	7.500	7.750	2.630 x 3.630	3/8-16	Electro-Plated	5.240

Position Floor Locks

- 15 Series compatible
- Can be mounted to the profile T-slot or end by using base plates – page 472
- Immobilize equipment with 70-100 lbs. force per lock through spring-loaded rubber foot pad
- When properly applied, frame will not lift off floor

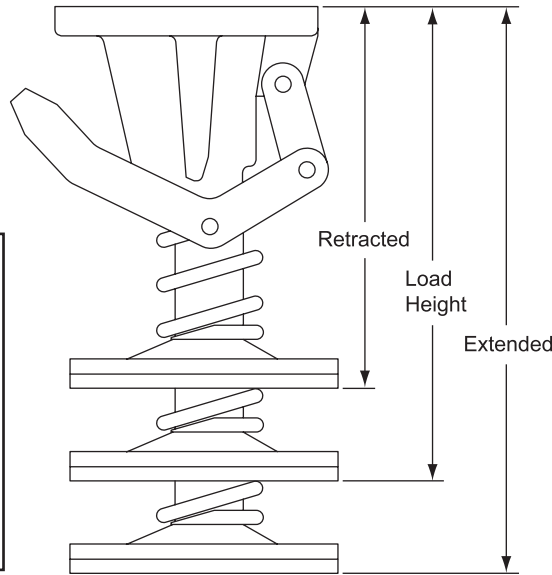

Recommended Mounting Hardware (Floor Lock to Base Plate):

Part No.	Bolt Kit	Quantity	Description
2727	3289	4	3/8-16 x 1" SHCS & Washer
2728	3291	4	1/2-13 x 1" SHCS & Washer

Part No.	Base Plate Part No.	Retracted	Load Height	Extended	Bolt Hole Spacing	Bolt Diameter	Finish	Lbs.
2727	2148	4.625	5.500	5.875	2.630 x 3.630	3/8-16	Aluminum Lacquer	7.500
2728	2149	6.750	7.625	8.250	2.440 x 4.940	1/2-13	Aluminum Lacquer	10.700

Position Floor Locks *continued*

These position floor locks are designed to immobilize equipment at a desired location. When the position floor locks are not in use, they remain attached without interfering with mobility.

Fixture dollies, carts, or other castered applications can be locked in place by a simple foot pressure. The locking action is created when the friction surface of nearly ten square inches is pressed against the floor with 70-100 pounds of force.



Proper Application:

When the weight of your application is 100 pounds or more per floor lock, the floor lock will remain locked in position properly.

Improper Application:

When the weight of your application is less than 100 pounds per floor lock, the floor lock may raise the casters off the floor. This is not correct. If you have questions or need design assistance call 80/20® or your local distributor for more information.

Installation Information:

Example A

When a piece of equipment has two swivel and two rigid casters, only one position lock is needed

Example B

When there are four swivel casters on a piece of equipment, use at least two position floor locks mounted diagonally to each other

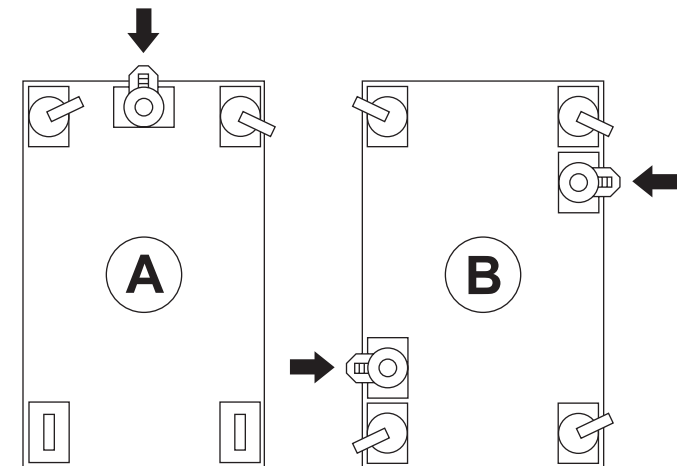

Position Floor Lock Base Plates



- 15 Series compatible
- Mounts both types of position floor locks to profile T-slots or ends
- Made of 6105-T5 clear anodized aluminum
- Mounts position floor locks on pages 469-470

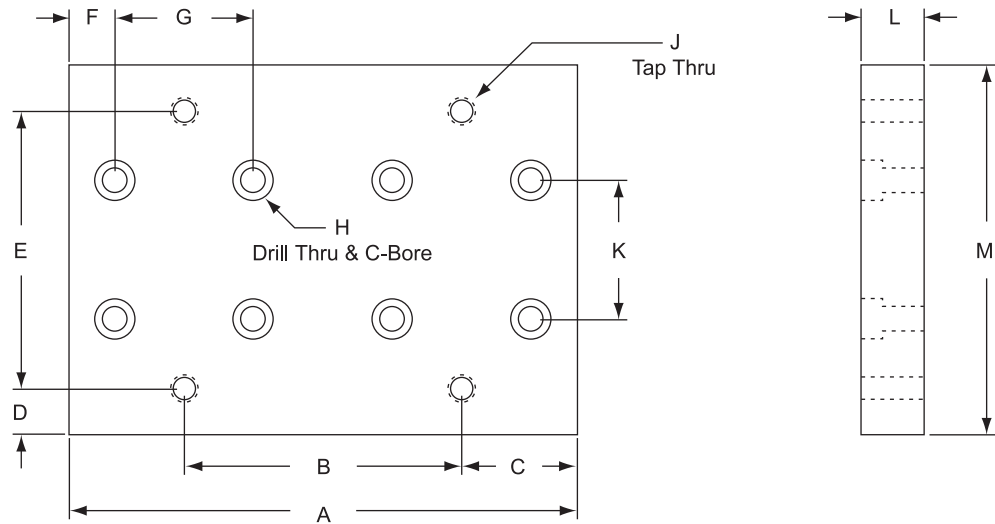
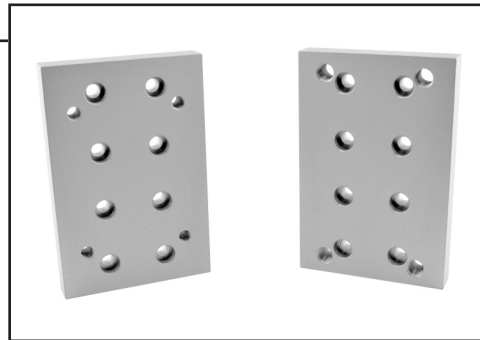

80/20® Design Tip

When mounting four swivel casters on a structure, use at least two position locks mounted diagonally to each other. When mounting two swivel and two rigid casters, only one position lock is needed.

Recommended Mounting Hardware (Mount to T-Slot):

Bolt Kit	Quantity	Description
3458	4 - 8	5/16-18 x 7/8" SHCS & Econ T-Nut

Recommended Mounting Hardware (Mount to Profile End):

Bolt Kit	Quantity	Description
3123	4 - 8	5/16-18 x 1 1/4" SHCS

Part No.	A	B	C	D	E	F	G	H	J	K	L	M	Lbs.
2148	6.000	3.625	1.188	.688	2.625	.750	1.500	5/16-18	3/8-16 SHCS	1.500	.750	4.000	1.505
2149	6.000	5.000	.531	.750	2.500	.750	1.500	5/16-18	1/2-13 SHCS	1.500	.750	4.000	1.495

Furniture Style Glides



- 10 and 15 Series compatible
- Best used on soft floor surfaces
- Black nylon glides have 100 lbs. load capacity
- Non-corrosive threaded stem mounts directly to profile end
- See page 564 for tapping service

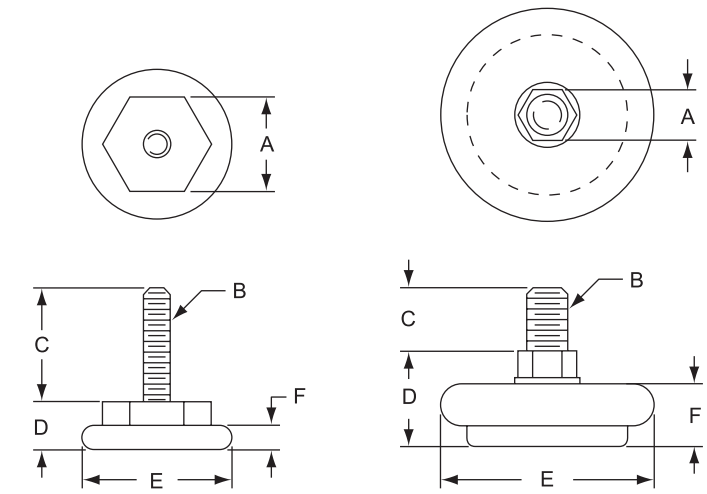
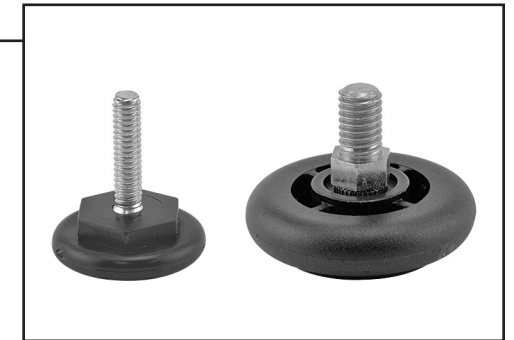

2203

2204

Part No.	A	B	C	D	E	F	Lbs.
2203	.875	1/4-20	1.070	.430	1.350	.240	.030
2204	.470	.580	3/8-16	.880	.575	1.960	.090

☒ = 10 Series Compatible Part

Economy Furniture Glides

- 10 and 15 Series compatible
- Threads into profile end or can be mounted with base plates
- Nickel-plated with non-abrasive nylon base
- Cost-effective, modular solution for light-duty applications
- See page 564 for tapping services

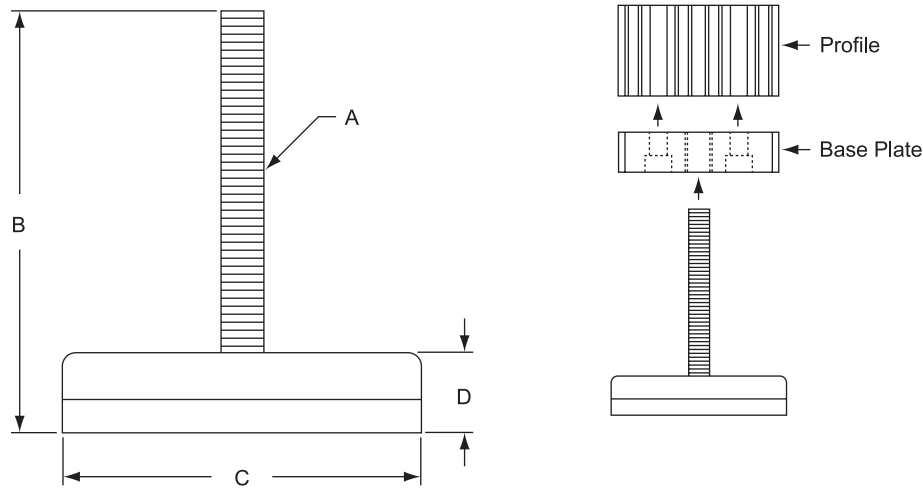

Part No.	Load Capacity	A	B	C	D	Lbs.
2186	250 Lbs.	1/4-20	1.870	1.200	.378	.041
2187	250 Lbs.	5/16-18	2.570	2.030	.578	.139
2188	250 Lbs.	3/8-16	2.460	2.400	.468	.179
2189	500 Lbs.	1/2-13	2.540	2.800	.542	.269

Large Base Glides



- 10 and 15 Series compatible
- Mount to profile with base plates on pages 480-483
- Zinc-plated stud with glass-filled nylon base
- 4000-5000 lb. load capacity for leveling heavier applications
- Extra large base diameter creates maximum surface area
- Stems swivel 15° in all directions
- See page 564 for tapping services

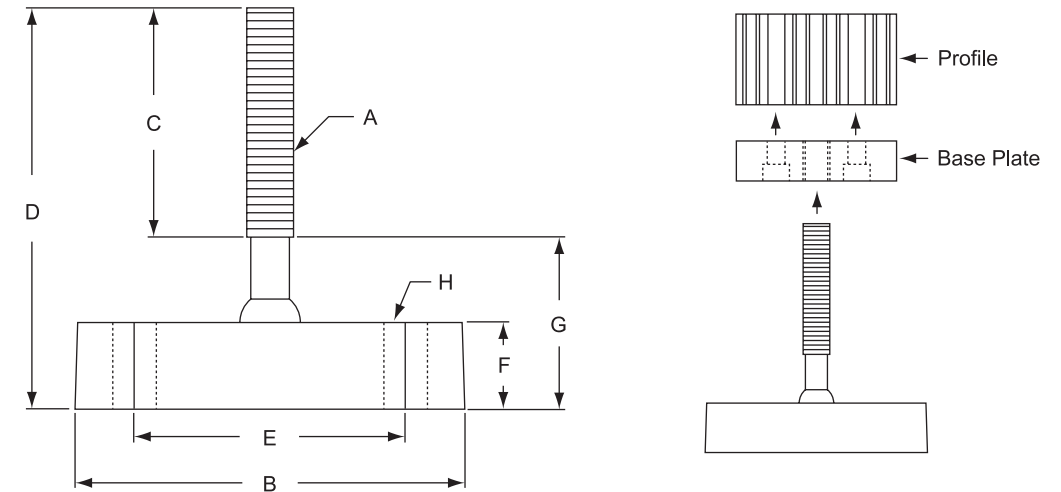

Part No.	Load Capacity	A	B	C	D	E	F	G	H	Lbs.
2183	4000 Lbs.	3/8-16	1.970	3.000	4.430	1.320	.700	1.430	.256	.184
2184	4000 Lbs.	1/2-13	1.970	3.000	4.430	1.320	.700	1.430	.256	.256
2181	5000 Lbs.	3/8-16	3.150	3.000	4.430	2.190	.700	1.430	.354	.266
2182	5000 Lbs.	1/2-13	3.150	3.000	4.430	2.190	.700	1.430	.354	.338

80/20® Inc.
The Industrial Erector Set®
THE STANDARD



Mighty Mount™

- 10 and 15 Series compatible
- Zinc-plated lock nut and bolt included
- High vibration and shock isolation with non-skid elastomer pad
- 300 - 4200 lbs. maximum load capacity range
- Powder coated safety yellow steel housing
- Works great with leveling anchor base plates shown on pages 484-487
- See page 564 for tapping services

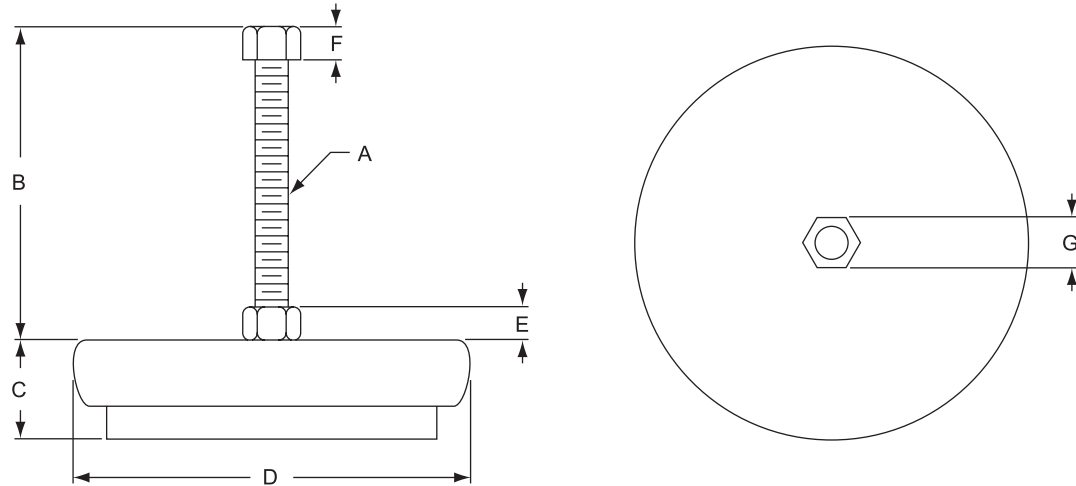

Part No.	Load Range	A	B	C	D	E	F	G	Lbs.
2215	100 / 300 Lbs.	3/8-16	2.250	1.500	3.000	.375	.250	.563	1.140
2216	500 / 1500 Lbs.	1/2-13	4.250	1.500	5.000	.438	.375	.750	2.760
2217	1000 / 4200 Lbs.	3/4-10	4.250	1.630	6.000	.688	.500	1.125	5.820

Note: Dimensions are free height of mount before leveling with leveling bolt. Mighty Mount® is a registered trademark of Willimount Corp.

Fractional

Economy Anti-Vibration Mounts



- 10 and 15 Series compatible
- Gold irridite finish with black rubber anti-vibration pad
- 100 - 650 lbs. load capacity range
- Level high-precision or computerized machinery
- See page 480-483 for base plates
- See page 564 for tapping services

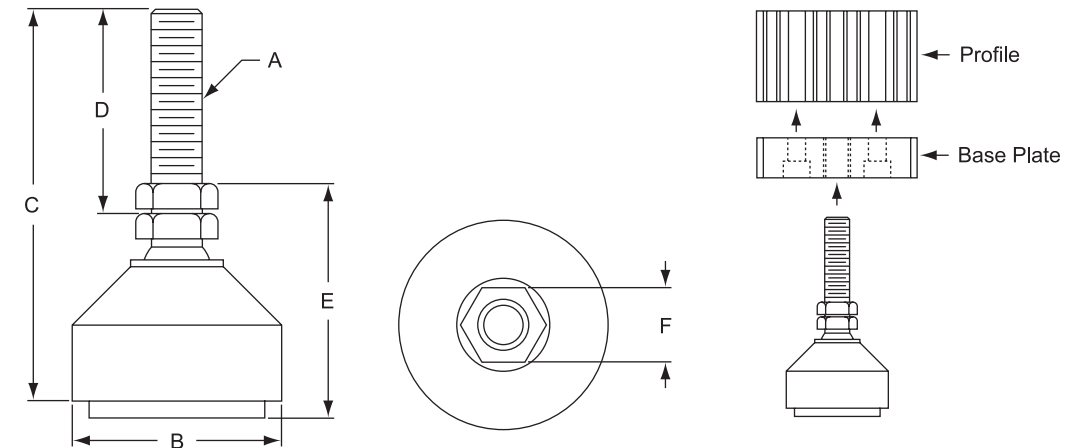

Part No.	Load Capacity	A	B	C	D	E	F	Lbs.
2207	100 Lbs.	3/8-16	1.250	3.500	2.000	1.500	.562	.320
2208	240 Lbs.	1/2-13	1.875	3.750	2.000	1.750	.625	.800
2209	650 Lbs.	3/4-10	3.000	4.125	2.000	2.125	1.062	2.380

80/20® Inc.
The Industrial Erector Set®
THE STANDARD

Deluxe Leveling Feet



- 10 and 15 Series compatible
- 1000-7400 lbs. Load capacity range
- Threads directly into tapped profile end; jam nut included
- Pivots 20° to accommodate uneven floors
- Base plates can also be used for mounting feet to T-slotted profiles – see page 480-483
- See page 564 for tapping services

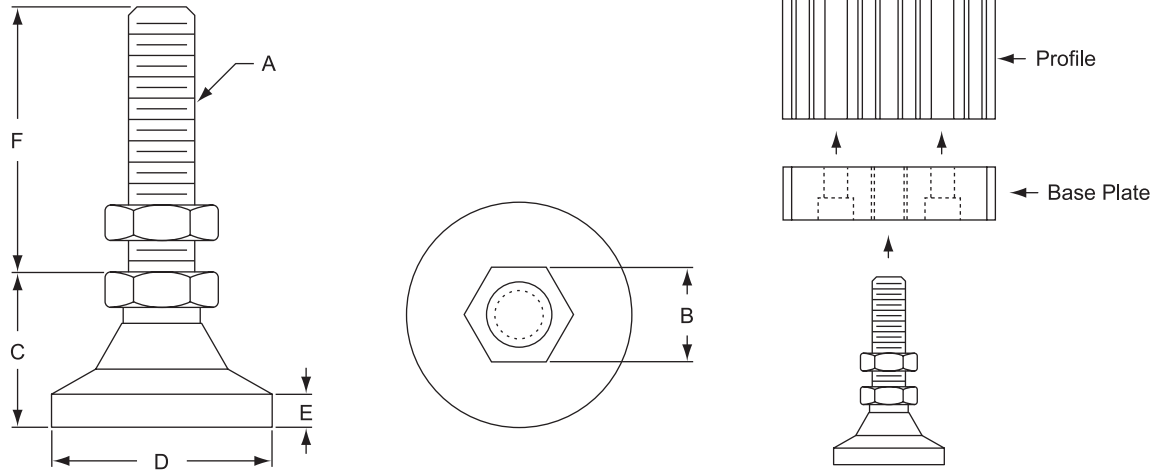

Part No.	Load Capacity	A	B	C	D	E	F	Lbs.
2192	1000 Lbs.	1/4-20	.500	.703	1.000	.156	1.250	.100
2194	2300 Lbs.	5/16-18	.625	.875	1.250	.188	2.000	.220
2190	3750 Lbs.	3/8-16	.625	.875	1.250	.188	2.000	.220
2200	5000 Lbs.	1/2-13	.750	1.125	1.875	.250	2.000	.510
2202	7400 Lbs.	3/4-10	1.062	1.500	3.000	.500	2.000	1.680

☒ = 10 Series Compatible Part

Fractional

Economy Leveling Feet



- 10 and 15 Series compatible
- Threads directly into tapped profile end; jam nut included
- 1050-4700 lbs. load capacity range
- Base plates can also be used for mounting feet onto T-slotted profiles – see page 480-483
- See page 564 for tapping services

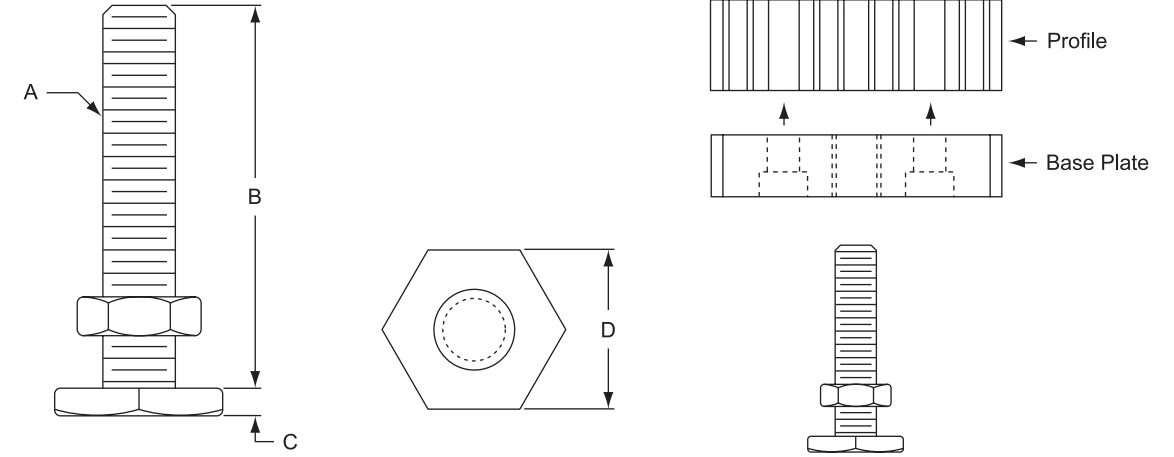
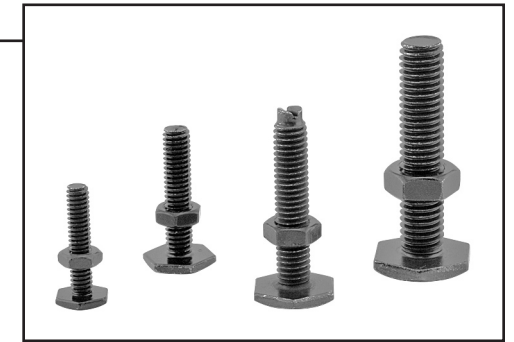

Part No.	Load Capacity	A	B	C	D	Lbs.
2193	1050 Lbs.	1/4-20	1.250	.094	.563	.025
2195	1750 Lbs.	5/16-18	1.500	.109	.750	.050
2191	2550 Lbs.	3/8-16	2.000	.141	.875	.085
2201	4700 Lbs.	1/2-13	2.500	.172	1.063	.180

☒ = 10 Series Compatible Part

10 Series Base Plates



- 10 Series compatible
- Mounts leveling feet and threaded stem casters to profile
- Made of 6105-T5 clear anodized aluminum
- Attach to profile end or T-slot



⊗ = 10 Series Compatible Part

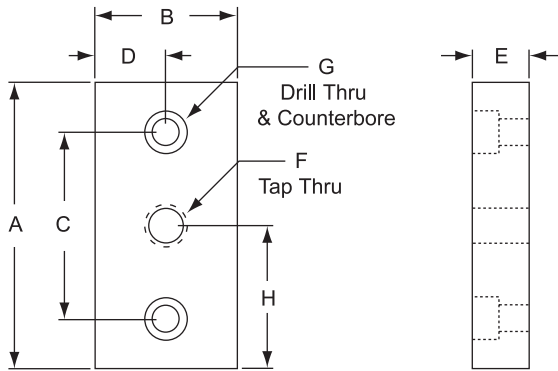

Part Numbers:

- 2124 ⊗
- 2128 ⊗
- 2129 ⊗
- 2137 ⊗
- 2361 ⊗

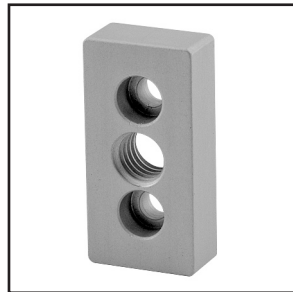

Part No.	A	B	C	D	E	F	G	H	Lbs.
2124 ⊗	2.000	1.000	1.000	.500	.500	5/16-18	1/4-20 SHCS	1.000	.087
2128 ⊗	2.000	1.000	1.000	.500	.500	1/4-20		1.000	.090
2129 ⊗	2.000	1.000	1.000	.500	.500	3/8-16		1.000	.085
2137 ⊗	2.000	1.000	1.000	.500	.500	7/16-14		1.000	.080
2361 ⊗	2.000	1.000	1.000	.500	.500	1/2-13		1.000	.078

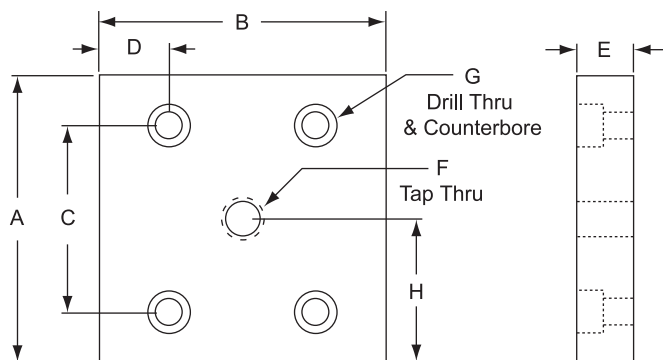

Part Numbers:

- 2127 ⊗
- 2131 ⊗
- 2132 ⊗
- 2139 ⊗
- 2362 ⊗

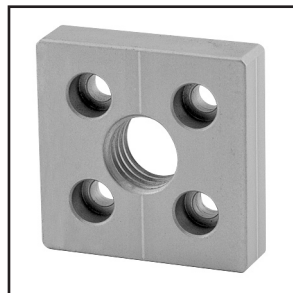

Part No.	A	B	C	D	E	F	G	H	Lbs.
2127 ⊗	2.000	2.000	1.000	.500	.500	5/16-18	1/4-20 SHCS	1.000	.180
2131 ⊗	2.000	2.000	1.000	.500	.500	3/8-16		1.000	.175
2132 ⊗	2.000	2.000	1.000	.500	.500	1/2-13		1.000	.170
2139 ⊗	2.000	2.000	1.000	.500	.500	7/16-14		1.000	.170
2362 ⊗	2.000	2.000	1.000	.500	.500	3/4-10		1.000	.160

10 Series Base Plates continued

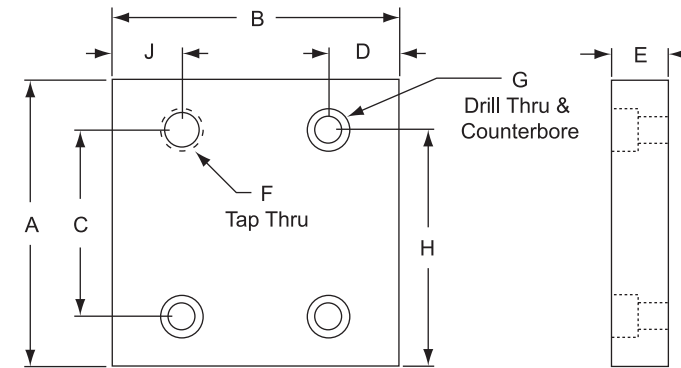

Part Numbers:

- 2136 ⊗
- 2142 ⊗
- 2143 ⊗
- 2363 ⊗
- 2364 ⊗

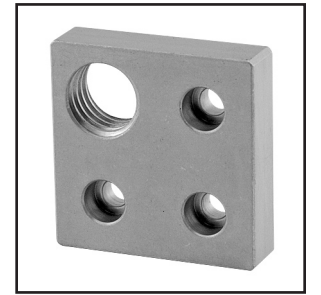

Part No.	A	B	C	D	E	F	G	H	J	Lbs.
2136 ⊗	2.000	2.000	1.000	.500	.500	5/16-18	1/4-20 SHCS	1.500	.500	.185
2142 ⊗	2.000	2.000	1.000	.500	.500	3/8-16		1.500	.500	.180
2143 ⊗	2.000	2.000	1.000	.500	.500	7/16-14		1.500	.500	.175
2363 ⊗	2.000	2.000	1.000	.500	.500	1/2-13		1.500	.500	.172
2364 ⊗	2.000	2.000	1.000	.500	.500	3/4-10		1.500	.500	.162

⊗ = 10 Series Compatible Part

Recommended Mounting Hardware (Mount to T-Slot):

Part No.	Bolt Kit	Qty	Description
2124 ⊗	3491	2	1/4-20 x 1/2" SHCS & Econ T-Nut
2128 ⊗			
2129 ⊗			
2137 ⊗			
2361 ⊗			
2127 ⊗	3491	4	1/4-20 x 1/2" SHCS & Econ T-Nut
2131 ⊗			
2132 ⊗			
2139 ⊗			
2362 ⊗	3491	3	1/4-20 x 1/2" SHCS & Econ T-Nut
2136 ⊗			
2142 ⊗			
2143 ⊗			
2363 ⊗			
2364 ⊗			

Recommended Mounting Hardware (Mount to Profile End):

Part No.	Bolt Kit	Qty	Description
2124 ⊗	3064	2	1/4-20 x 3/4" SHCS
2128 ⊗			
2129 ⊗			
2137 ⊗			
2361 ⊗			
2127 ⊗	3064	4	1/4-20 x 3/4" SHCS
2131 ⊗			
2132 ⊗			
2139 ⊗			
2362 ⊗			
2136 ⊗			
2142 ⊗			
2143 ⊗			
2363 ⊗			
2364 ⊗			

Note: Corner tap base plate should **NOT** be mounted to the profile end

15 Series Base Plates



- 15 Series compatible
- Mounts leveling feet and threaded stem casters into profile
- Made of 6105-T5 clear anodized aluminum
- Attach to profile end or T-slot

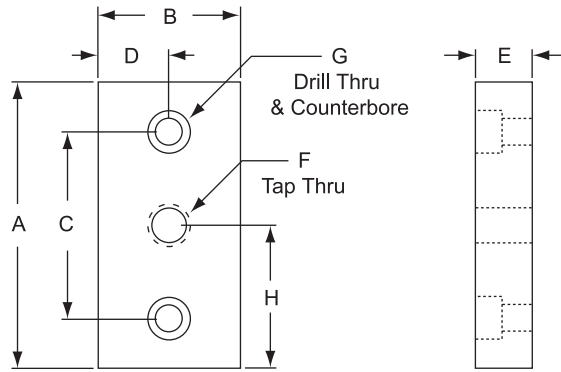

Part Numbers:
2130
2135
2138
2365

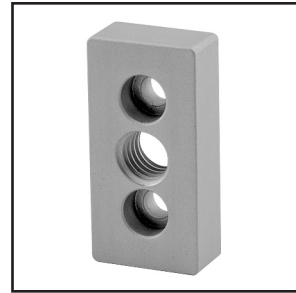

Part No.	A	B	C	D	E	F	G	H	Lbs.
2130	3.000	1.500	1.500	.750	.750	3/8-16	5/16-18 SHCS	1.500	.300
2135	3.000	1.500	1.500	.750	.750	1/2-13		1.500	.300
2138	3.000	1.500	1.500	.750	.750	7/16-14		1.500	.300
2365	3.000	1.500	1.500	.750	.750	3/4-10		1.500	.286

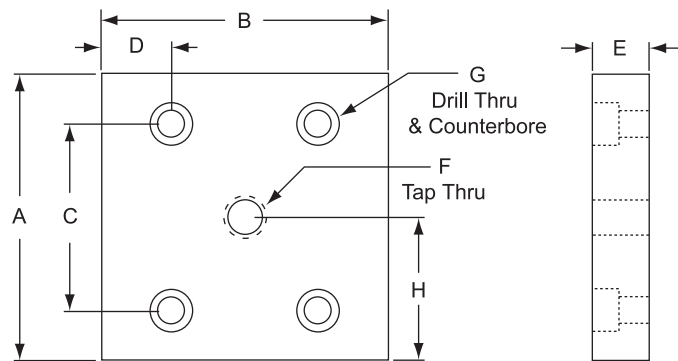

Part Numbers:
2140
2145
2366

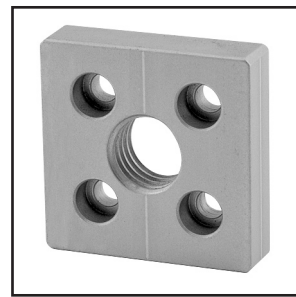

Part No.	A	B	C	D	E	F	G	H	Lbs.
2140	3.000	3.000	1.500	.750	.750	1/2-13	5/16-18 SHCS	1.500	.600
2145	3.000	3.000	1.500	.750	.750	7/16-14		1.500	.600
2366	3.000	3.000	1.500	.750	.750	3/4-10		1.500	.580

15 Series Base Plates continued

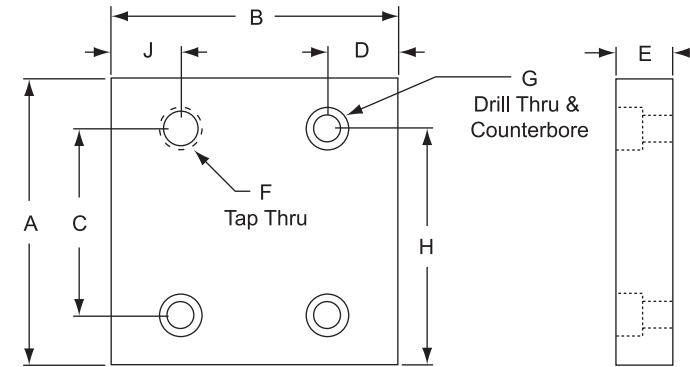

Part Numbers:
2141
2146
2367

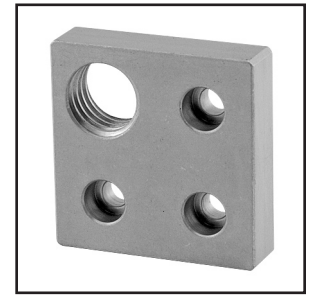

Part No.	A	B	C	D	E	F	G	H	J	Lbs.
2141	3.000	3.000	1.500	.750	.750	1/2-13	5/16-18 SHCS	2.250	.750	.610
2146	3.000	3.000	1.500	.750	.750	7/16-14		2.250	.750	.610
2367	3.000	3.000	1.500	.750	.750	3/4-10		2.250	.750	.600

Recommended Mounting Hardware (Mount to T-Slot):

Part No.	Bolt Kit	Qty	Description
2130	3458	2	5/16-18 x 7/8" SHCS & Econ T-Nut
2135			
2138			
2365			
2140	3458	4	5/16-18 x 7/8" SHCS & Econ T-Nut
2145			
2366			
2141			
2146	3458	3	5/16-18 x 7/8" SHCS & Econ T-Nut
2367			

Recommended Mounting Hardware (Mount to Profile End):

Part No.	Bolt Kit	Qty	Description
2130	3123	2	5/16-18 x 1 1/4" SHCS
2135			
2138			
2365			
2140	3123	4	5/16-18 x 1 1/4" SHCS
2145			
2366			
2141			
2146	—	—	Note: Corner tap base plate should NOT be mounted to the profile end
2367			

10 Series Leveling/Anchoring Base Plates

- 10 Series compatible
- Provides offset hole to anchor fixture to floor
- Made of 6105-T5 clear anodized aluminum
- Mounts leveling feet onto most 80/20® T-slotted profile ends
- Use with wedge floor anchors on page 492



☒ = 10 Series Compatible Part

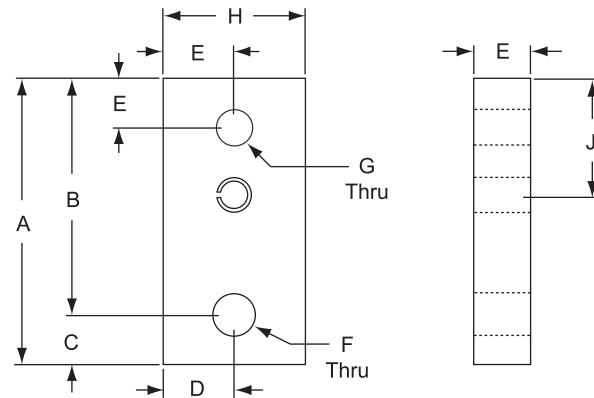

Part Number:
2166 ☒

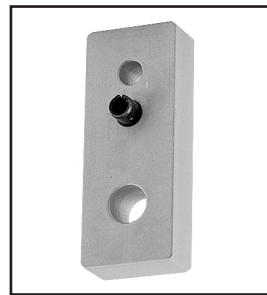

Part No.	A	B	C	D	E	F	G	H	J	Lbs.
2166 ☒	2.500	1.875	.625	.500	.500	ø.390	ø.257	1.000	.940	.120

10 Series Leveling / Anchoring Base Plates continued

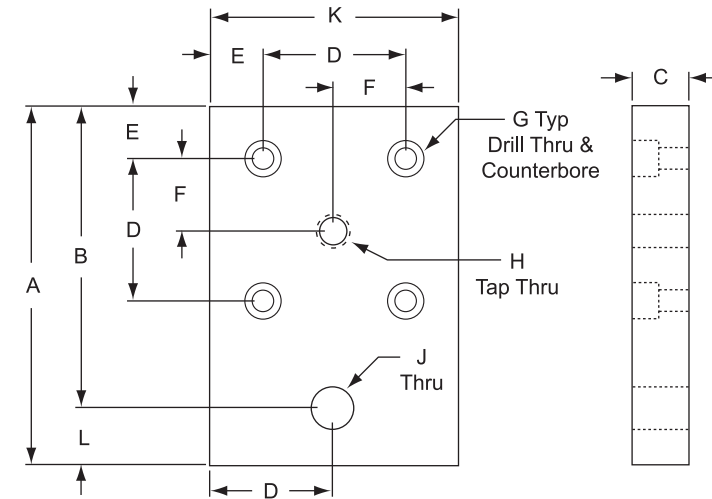

Part Number:
2169 ☒
2171 ☒

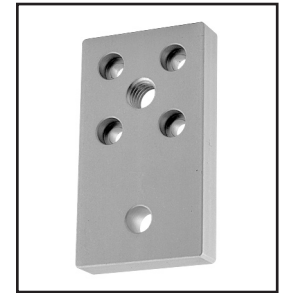

Part No.	A	B	C	D	E	F	G	H	J	K	L	Lbs.
2169 ☒	3.500	2.875	.500	1.000	.500	.500	1/4-20 SHCS	3/8-16	ø.390	2.000	.625	.315
2171 ☒	3.500	2.875	.500	1.000	.500	.500	1/4-20 SHCS	1/2-13	ø.390	2.000	.625	.310

☒ = 10 Series Compatible Part

Recommended Mounting Hardware (Mount to T-Slot):

Part No.	Bolt Kit	Qty	Description
2166	—	—	—
2167	3491	2	1/4-20 x 1/2" SHCS & Econ T-Nut
2168	—	—	—
2169	3491	4	1/4-20 x 1/2" SHCS & Econ T-Nut
2171	—	—	—

Recommended Mounting Hardware (Mount to Profile End):

Part No.	Bolt Kit	Qty	Description
2166	—	—	—
2167	3064	2	1/4-20 x 3/4" SHCS
2168	—	—	—
2169	3064	4	1/4-20 x 3/4" SHCS
2171	—	—	—

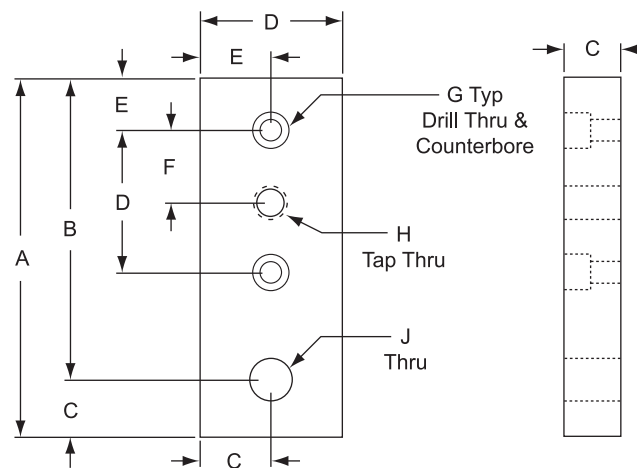

Part Number:
2167 ☒
2168 ☒

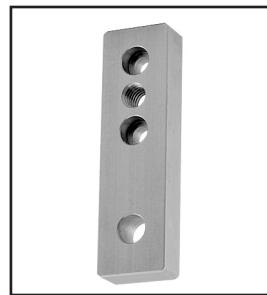

Part No.	A	B	C	D	E	F	G	H	J	Lbs.
2167 ☒	3.500	2.875	.500	1.000	.500	.500	1/4-20 SHCS	1/4-20	ø.390	.155
2168 ☒	3.500	2.875	.500	1.000	.500	.500	1/4-20 SHCS	3/8-16	ø.390	.155

15 Series Leveling/Anchoring Base Plates

- 15 Series compatible
- Provides an offset hole to anchor your frame to floor
- Made of 6105-T5 clear anodized aluminum
- Mounts leveling feet onto most 80/20® T-slotted profile ends
- Use with wedge floor anchors on page 492

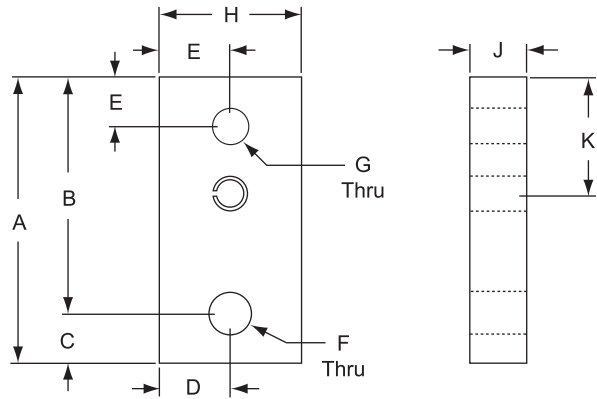

Part Number:
2165

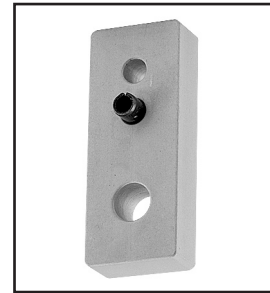

Part No.	A	B	C	D	E	F	G	H	J	K	Lbs.
2165	3.000	2.500	.500	.750	.750	ø.531	ø.390	1.500	.500	1.410	.205

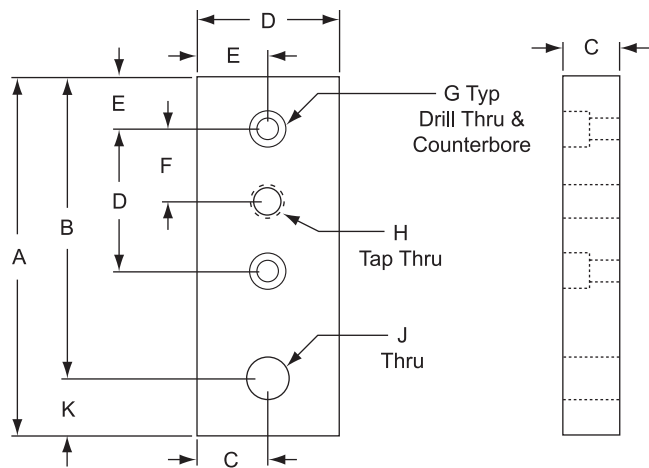

Part Number:
2170
2175

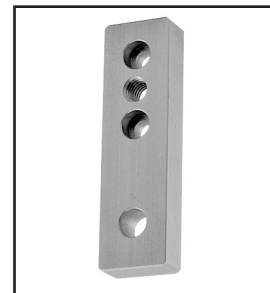

Part No.	A	B	C	D	E	F	G	H	J	K	Lbs.
2170	4.500	4.000	.750	1.500	.750	.750	5/16-18 SHCS	3/8-16	ø.531	.500	.445
2175	4.500	4.000	.750	1.500	.750	.750	5/16-18 SHCS	1/2-13	ø.531	.500	.445

15 Series Leveling / Anchoring Base Plates continued

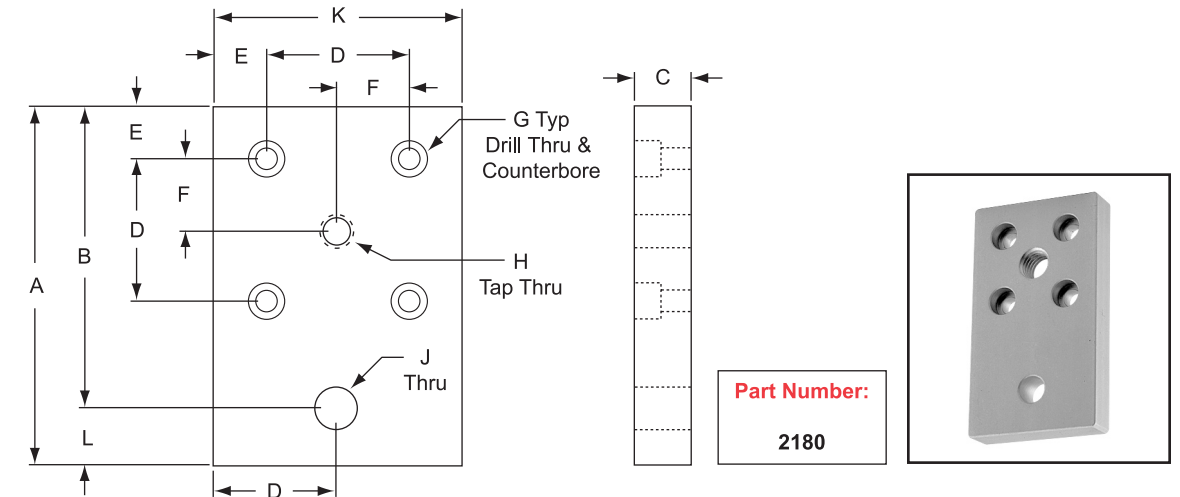

Part Number:
2180



Part No.	A	B	C	D	E	F	G	H	J	K	L	Lbs.
2180	4.500	4.000	.750	1.500	.750	.750	5/16-18 SHCS	1/2-13	ø.531	3.000	.500	.920

Recommended Mounting Hardware (Mount to T-Slot):

Part No.	Bolt Kit	Qty	Description
2165	—	—	—
2170	3458	2	5/16-18 x 7/8" SHCS & Econ T-Nut
2175	—	—	—
2180	3458	4	5/16-18 x 7/8" SHCS & Econ T-Nut

Recommended Mounting Hardware (Mount to Profile End):

Part No.	Bolt Kit	Qty	Description
2165	—	—	—
2170	3123	2	5/16-18 x 1 1/4" SHCS
2175	—	—	—
2180	3123	4	5/16-18 x 1 1/4" SHCS

Base for Swivel Feet
Stainless Steel - SS 304

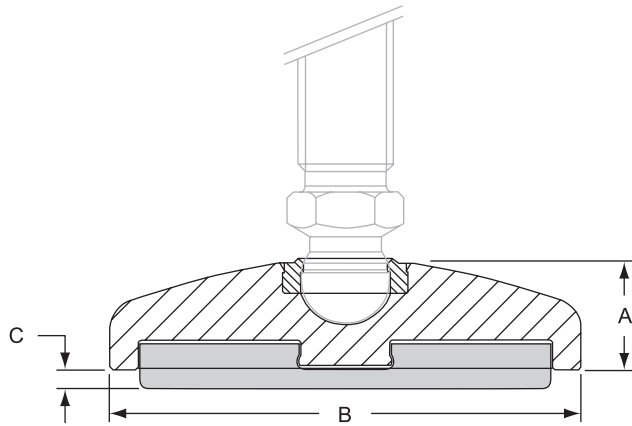

- Heavy-duty leveling feet have anti-slip rubber pads
- These bases require threaded stems shown on page 489

Part No. with Anti-Slip Plate	Base	A	B	C	Max. Load / Lbs.	Lbs.
12170	1.181	.709	1.142	.118	4400.00	.14
12172	1.575		1.535		6600.00	.22
12174	1.772		1.732		6600.00	.27
12176	1.969		1.929		7700.00	.35
12178	2.362		2.323		7700.00	.48
12182	3.150		3.110		7700.00	.84
12186	3.937		3.898		8800.00	1.33

Base for Swivel Feet
Stainless Steel - SS 304

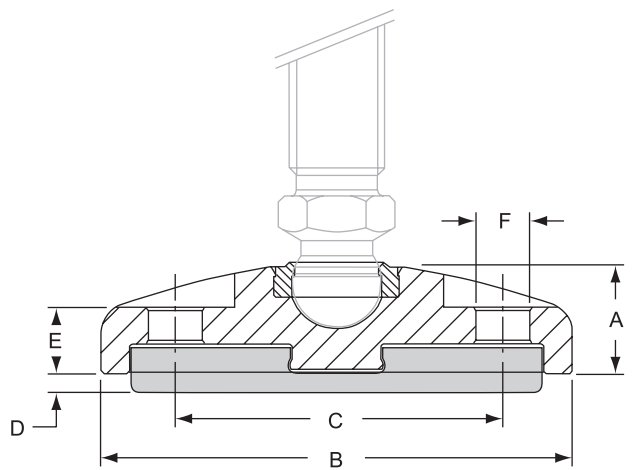

- Heavy-duty leveling feet with floor mount holes
- Anti-slip rubber pads included
- These bases require threaded stems shown on page 489
- See page 492 for wedge floor anchors

Part No. with Anti-Slip Plate	Base	A	B	C	D	E	F	Max. Load / Lbs.	Lbs.
12181	3.150	.709	3.110	2.165	.118	.433	.354	6600.00	.78
12185	3.937		3.898	2.913				8800.00	1.29

Threaded Stems for Swivel Feet
Zinc-Plated Steel & Stainless Steel - SS 304



- Metric and fractional threads
- Zinc-plated or stainless steel
- Use with swivel bases on page 386



Stainless Steel Part No.	Zinc-Plated Steel Part No.	Threaded Rod UNC	L	Max. Load / Lbs.	Lbs.	Spanner Width (SW)	H
12229	12230	1/4-20	1.50	400.00	.07	9/16"	.295
12245	12246	5/16-18	1.50	700.00	.08	9/16"	.295
12247	12248	5/16-18	2.50	700.00	.10	9/16"	.295
12249	12250	5/16-18	3.50	700.00	.12	9/16"	.295
12237	12238	3/8-16	1.50	1000.00	.10	9/16"	.295
12239	12240	3/8-16	2.50	1000.00	.12	9/16"	.295
12241	12242	3/8-16	4.00	1000.00	.15	9/16"	.295
12243	-	3/8-16	6.00	1000.00	.20	9/16"	.295
12213	-	1/2-13	1.50	1600.00	.12	9/16"	.295
12215	12216	1/2-13	2.50	1600.00	.16	9/16"	.295
12217	12218	1/2-13	2.00	1600.00	.15	9/16"	.295
12221	12222	1/2-13	3.00	1600.00	.20	9/16"	.295
12223	12224	1/2-13	4.00	1600.00	.24	9/16"	.295
12227	12228	1/2-13	6.00	1600.00	.32	9/16"	.295
12231	12232	3/4-10	4.00	5300.00	.53	7/8"	.413
12233	12234	3/4-10	6.00	5300.00	.73	7/8"	.413

Stainless Steel Part No.	Zinc-Plated Steel Part No.	Threaded Rod	L	Max. Load / Lbs.	Gram (Lbs.)	Spanner Width (SW)	H
12195	12390	M8	1.575	700.00	36.00 (0.08)	9/16"	.295
12196	12392	M8	3.150	700.00	50.00 (0.11)	9/16"	.295
12197	12394	M10	1.772	1000.00	41.00 (0.09)	9/16"	.295
12198	12396	M10	3.543	1000.00	68.00 (0.15)	9/16"	.295
12200	12400	M12	1.772	1600.00	54.00 (0.12)	9/16"	.295
12201	12402	M12	3.937	1600.00	95.00 (0.21)	9/16"	.295
12203	12406	M16	2.598	3100.00	113.00 (0.25)	.669	.295
12204	12408	M16	4.921	3100.00	191.00 (0.42)	.669	.295

To assemble swivel bases and threaded stems shown on pages 488-491:

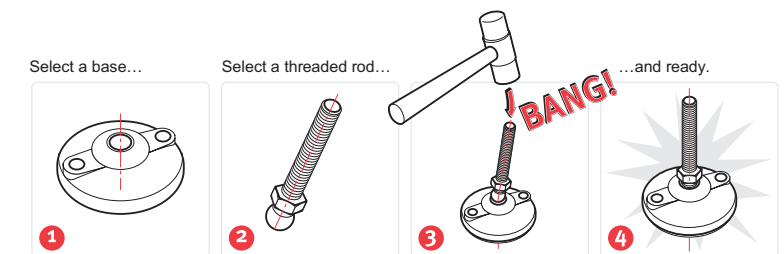

Extended Base for Swivel Feet
Die-Cast Zinc, Black Powder Coat

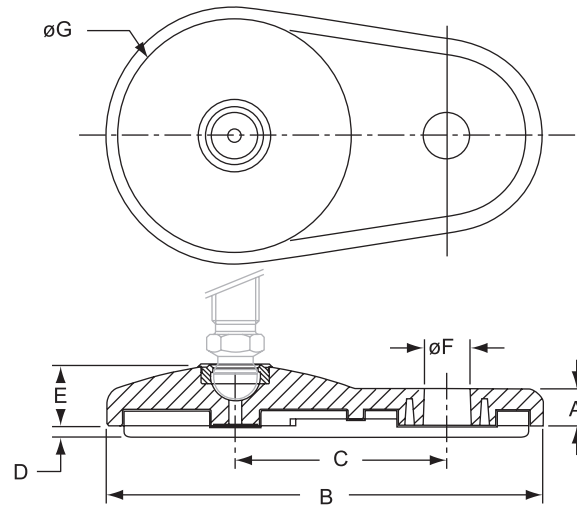

- High load capacity for heavy applications
- Attach to the floor with wedge floor anchors on page 492

Part No. with Anti-Slip Plate	Base	A	B	C	D	E	F	G	Max. Load / Lbs.	Lbs.
12192	3.110	.445	5.275	2.559	.118	.709	.551	3.110	6600.00	.88

To assemble swivel bases and threaded stems, see instructions on page 489.

Trapezoid Base for Swivel Feet
Die-Cast Zinc, Black Powder Coat

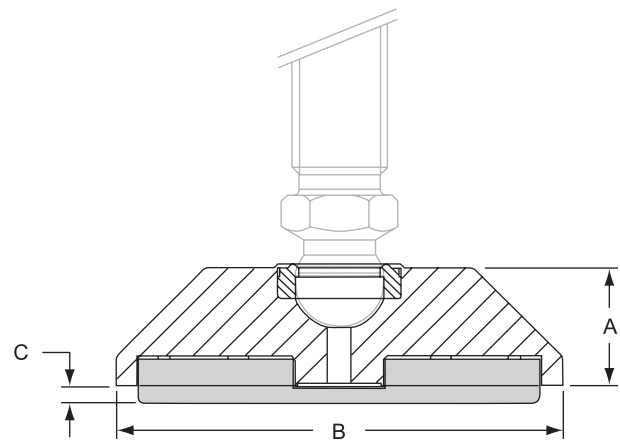

- Heavy-duty leveling base for uneven floors
- See page 489 for a large selection of threaded stems

Part No. with Anti-Slip Plate	A	B	C	Max. Load / Lbs.	Lbs.
12194	.787	3.150	.118	6600.00	.56

Ball Joint 15 for Swivel Feet
Zinc-Plated Steel & Stainless Steel - SS 304

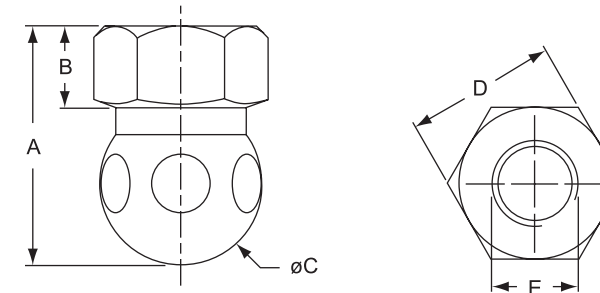

- Turns M8 or 1/4-20 screws into stems for swivel bases
- Available in zinc-plated or stainless steel

Stainless Steel Part No.	Zinc-Plated Steel Part No.	A	B	C	D	E (Thread)	Spanner Width (SW)	Lbs.
12209	12210	.866	.295	.590	.551	M8, .30 deep	9/16"	.04
12211	12212					1/4-20, .30 deep	9/16"	.04

Trapezoid Base Anchor
Die-Cast Zinc, Black Powder Coat

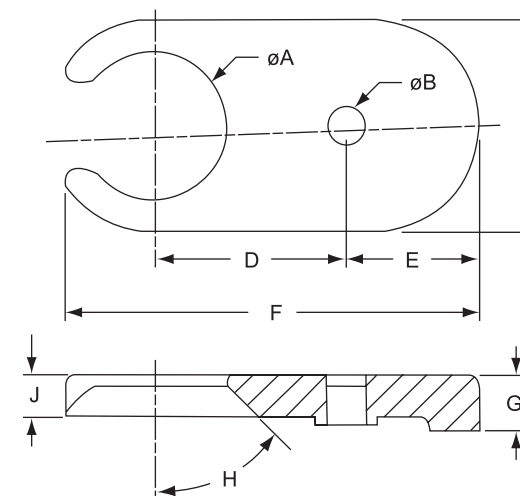

- Use with trapezoid base, Part No. 12194 shown on page 490
- Securely holds the base when using wedge floor anchors shown on page 492

Part No.	A	B	C	D	E	F	G	H	J	Floor Mounting for 12194	For Base	Lbs.
12168	2.126	.551	2.992	2.756	1.890	5.905	.787	45°	.590		3.150	1.07

To assemble swivel bases and threaded stems, see instructions on page 489.

Wedge Floor Anchors

- Mount fixture directly to solid concrete floor
- Hex nut and washer included
- Made of high-strength carbon steel
- Use with leveling anchor base plates on pages 484-487
- Values shown are average ultimate values; they are offered only as a guide and are not guaranteed.

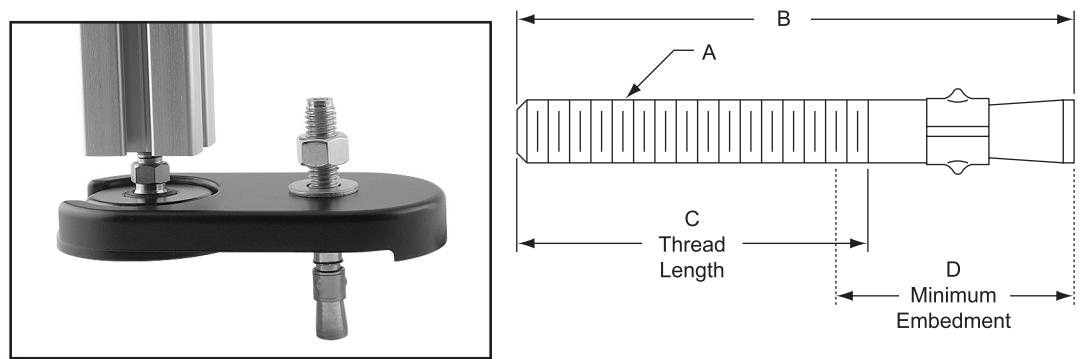
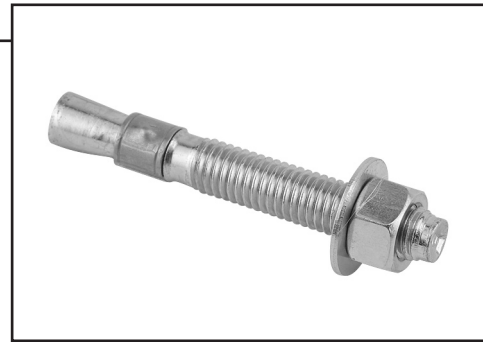

Part No.	A	B	C	D*	Tension (Lbs.)	Shear (Lbs.)	Lbs.
2904	1/4-20	1.750	0.750	1.125	1771.00	1813.00	.060
2905	1/4-20	3.250	2.250	1.125	2748.00	2813.00	.082
2901 ☒	3/8-16	2.750	1.625	1.500	3219.00	4029.00	.091
2902 ☒	3/8-16	3.750	2.625	1.500	5678.00	4305.00	.116
2903 ☒	3/8-16	5.000	3.875	1.500	5935.00	4581.00	.147
2906	1/2-13	3.750	2.250	2.250	5384.00	6900.00	.228
2907	1/2-13	5.500	3.000	2.250	7333.00	7449.00	.309
2908	1/2-13	7.000	4.500	2.250	9003.00	7998.00	.378

☒ = 10 Series Compatible Part

* (D) dimension is the minimum embedment.

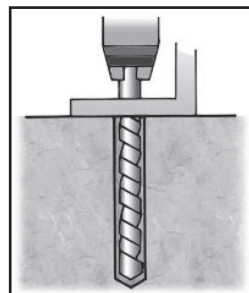

Step #1

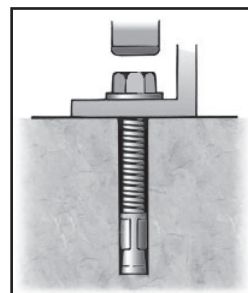

Step #2

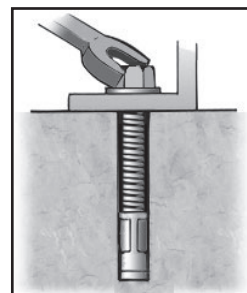

Step #3

- Step #1** Drill hole: Depth is embedment length plus 1/2". Diameter is the wedge anchor size. Clean out the hole.
Step #2 Thread nut on end of anchor to protect threads during installation. Hammer anchor to a depth so that threads are below the floor surface.
Step #3 Hand tighten nut, then 3 to 4 full turns with a wrench.

Floor Brackets

Die-Cast Zinc, Black Powder Coat

- 10, 15, 25, 30, 40 and 45 Series compatible
- Mounts to T-slot with recommended hardware listed below
- Fix profile to floor using wedge floor anchors on page 492

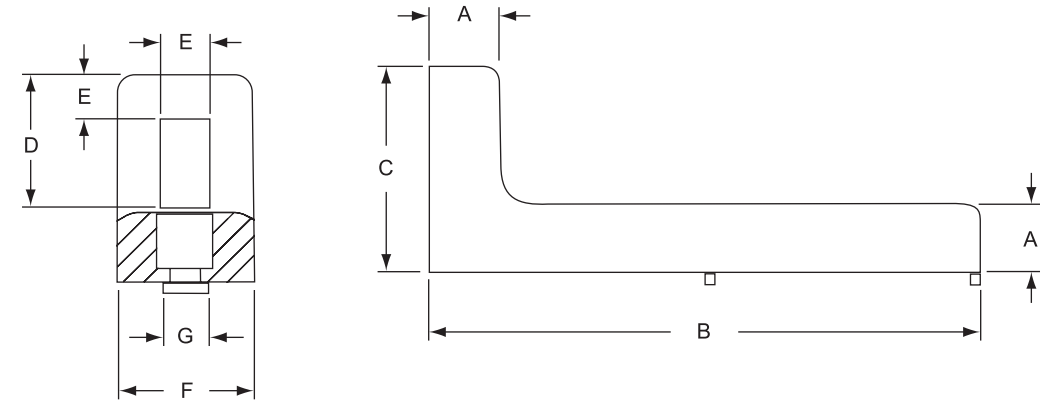
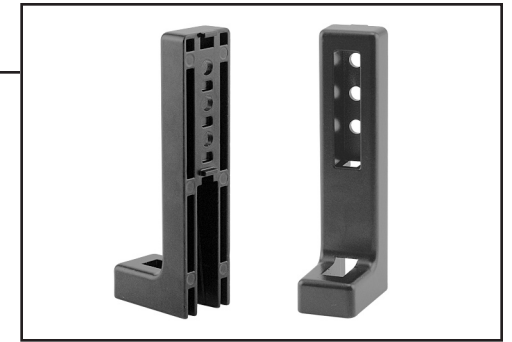

Part No.	Floor Bracket	A	B	C	D	E	F	G (Slot Tab)	Lbs.	Compatibility Code*
14000	1.772 x 4.724 x 1.181	.590	4.724	1.772	1.142	.394	1.181	.236	.48	6-10, 6-25
14002								.315		8-15, 8-30, 8-40
14006	2.362 x 6.299 x 1.496	.787	6.299	2.362	.984	.394	1.496	.315	1.03	8-15, 8-40

Recommended Fractional Mounting Hardware (Mount to T-slot):

Part No.	Bracket Part No.	Series	Qty	Description
3486	14000	10	2	1/4-20 x 3/8 SHCS & Econ. T-nut
3418	14002	15	2	1/4-20 x 5/8 BHSCS & Econ. T-nut
3462	14006	15	2	5/16-18 x 5/8 SHCS & Econ. T-nut

Recommended Metric Mounting Hardware (Mount to T-slot):

Part No.	Bracket Part No.	Series	Qty	Description
75-3520	14000	25	2	M6 x 10mm SHCS & Drop-In T-nut
75-3590	14002	30	2	M6 x 10mm SHCS & Drop-In T-nut
75-3593	14002	40	2	M6 x 14mm SHCS & Drop-In T-nut
75-3625	14006	40	2	M8 x 16mm SHCS & Slide-In T-nut

* See Compatibility Code information on page 152.

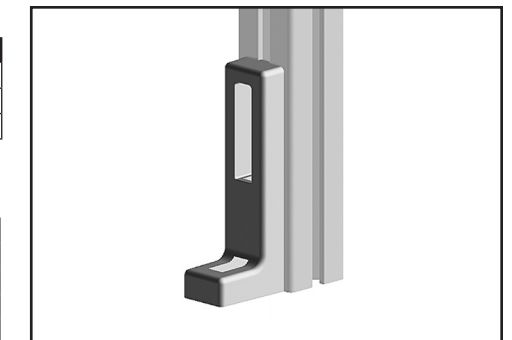

Adjustable Floor Brackets
Die-Cast Zinc, Black Powder Coat

- 10, 15, 25, 30, 40 and 45 series compatible
- Height adjustable screw in front activates stop plate in the slot on the back of the bracket
- Use wedge floor anchors on page 492 to fix to the floor

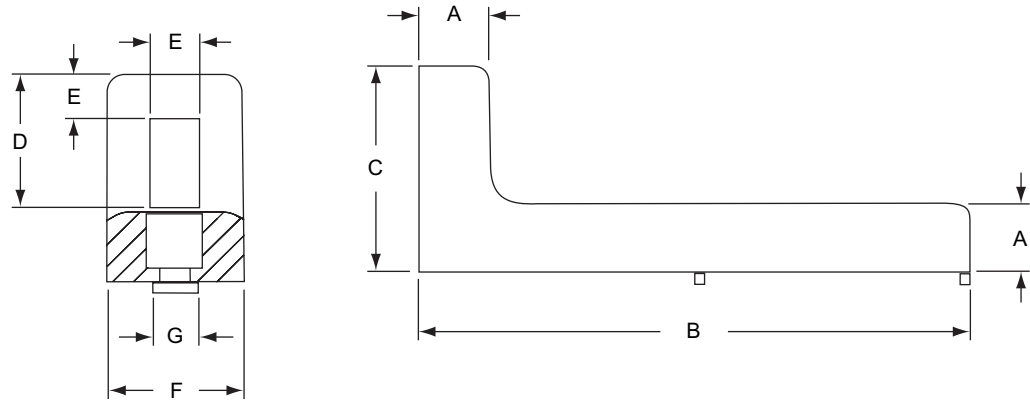

Part No.	Floor Bracket	A	B	C	D	E	F	G (Slot Tab)	Lbs.	Lifting Height	Compatibility Code*
14001	1.772 x 4.724 x 1.181	.590	4.724	1.772	1.142	.394	1.181	.236	.478	2.047	6-10-6-25
14003								.315			8-15, 8-30, 8-40
14007	2.362 x 6.299 x 1.496	.787	6.299	2.362	.984	.394	1.496	.315	1.100	2.835	8-15, 8-40

Recommended Fractional Mounting Hardware (Mount to T-slot):

Part No.	Bracket Part No.	Series	Qty	Description
3486	14001	10	2	1/4-20 x 3/8 SHCS & Econ. T-nut
3418	14003	15	2	1/4-20 x 5/8 BHSCS & Econ. T-nut
3462	14007	15	2	5/16-18 x 5/8 SHCS & Econ. T-nut

Recommended Metric Mounting Hardware: (Mount to T-slot):

Part No.	Bracket Part No.	Series	Qty	Description
75-3520	14001	25	2	M6 x 10mm SHCS & Drop-In T-nut
75-3590	14003	30	2	M6 x 10mm SHCS & Drop-In T-nut
75-3593	14003	40	2	M6 x 14mm SHCS & Drop-In T-nut
75-3625	14007	40	2	M8 x 16mm SHCS & Slide-In T-nut

* See Compatibility Code information on page 152.



Floor Mount Base Plates



- 10 and 15 Series compatible
- Made of 6105-T5 clear anodized aluminum
- Easily secure frame in place by adding wedge floor anchors found on page 492
- Strong, economical method of mounting frame to floor
- Allows for vertical adjustment by bolting directly to profile T-slots
- Base plate slots allow lateral adjustment

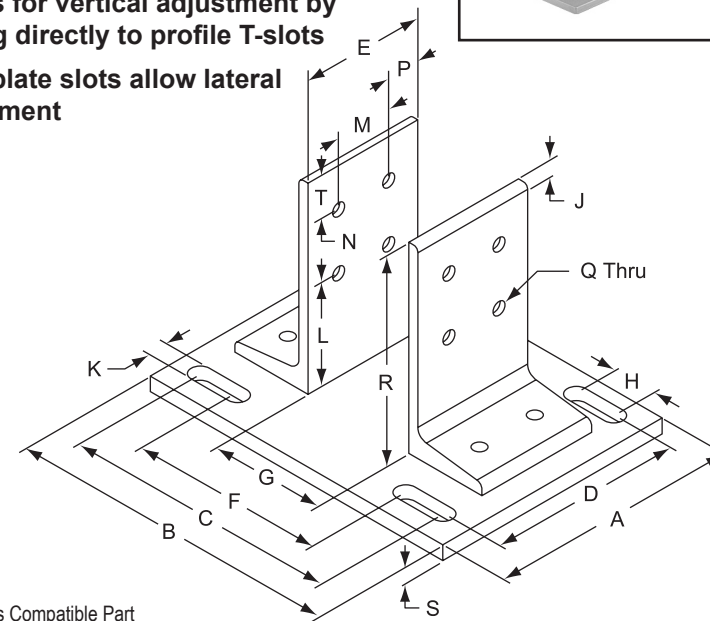
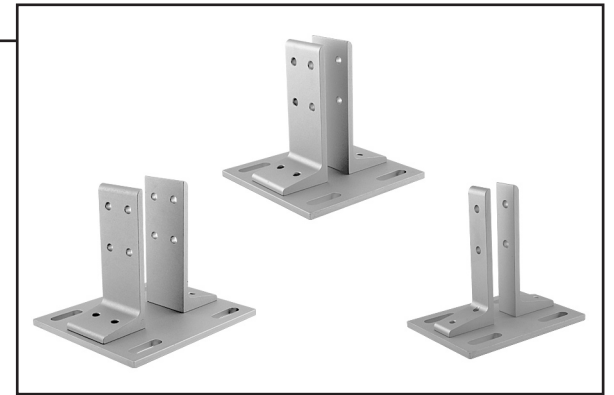

☒ = 10 Series Compatible Part

Part No.	A	B	C	D	E	F	G	H	J	K	L	M	N	P	Q	R	S	T	Lbs.
2380 ☒	4.000	5.500	4.250	2.750	1.000	2.250	1.000	1.000	.250	.406	2.750	—	1.500	.500	ø.281	5.000	.250	.750	.870
2385 ☒	5.500	5.500	4.250	4.250	2.000	2.250	1.000	1.000	.250	.406	2.750	1.000	1.500	.500	ø.281	5.000	.250	.750	1.555
2387 ☒	5.500	6.500	5.250	4.250	2.000	3.250	2.000	1.000	.250	.406	2.750	1.000	1.500	.500	ø.281	5.000	.250	.750	1.570
2390	5.000	6.000	4.750	3.750	1.500	2.750	1.500	1.000	.250	.531	2.750	—	1.500	.750	ø.328	5.000	.375	.750	1.555
2400	6.000	6.500	5.250	4.750	3.000	3.250	1.500	1.000	.250	.531	2.750	1.500	1.500	.750	ø.328	5.000	.375	.750	2.445
2410	6.000	8.000	6.750	4.750	3.000	4.750	3.000	1.000	.250	.531	2.750	1.500	1.500	.750	ø.328	5.000	.375	.750	2.770

Recommended Mounting Hardware (Mount to T-Slot):

Part No.	Description	Base Plate	Quantity
3321 ☒	1/4-20 FBHSCS & Economy T-Nut	2380 ☒	4
		2385 ☒	8
		2387 ☒	8
3325	5/16-18 Economy T-Slot Stud w/Washer & Hex Nut	2390	4
		2400	8
		2410	8
OR			
3320	5/16-18 FBHSCS & Economy T-Nut	2390	4
		2400	8
		2410	8

80/20® Inc.

The Industrial Erector Set®

THE STANDARD



Economy Floor Mount Base Plates

- 10 and 15 Series compatible
- Made of 6105-T5 clear anodized aluminum
- Allows for vertical adjustment by bolting directly to T-slot
- Strong, economical method of mounting frame to floor
- Easily secure frame in place by using wedge floor anchors on page 492

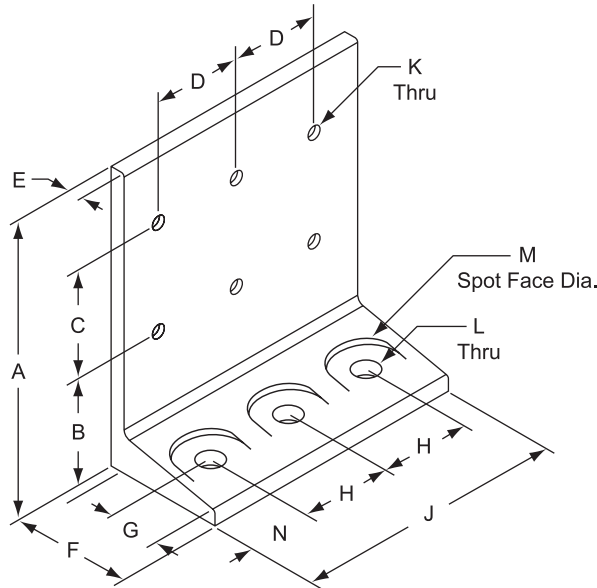
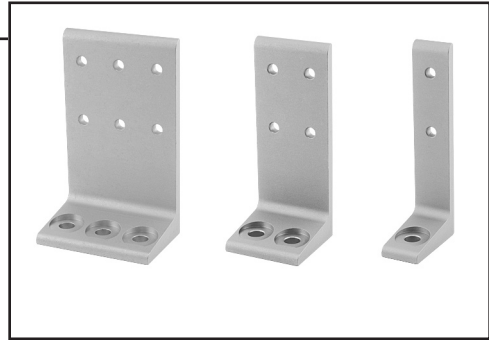

8

Part No.	A	B	C	D	E	F	G	H	J	K	L	M	N	Lbs.
2414	5.000	2.750	1.500	—	.250	2.000	.688	—	1.000	ø.257	ø.390	.875	.500	.175
2415	5.000	2.750	1.500	—	.250	2.000	.688	—	1.500	ø.328	ø.531	1.125	.750	.265
2416	5.000	2.750	1.500	1.000	.250	2.000	.688	1.000	2.000	ø.257	ø.390	.875	.500	.350
2417	5.000	2.750	1.500	1.500	.250	2.000	.688	1.500	3.000	ø.328	ø.531	1.125	.750	.530
2404	5.000	2.750	1.500	1.000	.250	2.000	.688	1.000	3.000	ø.257	ø.390	.875	.500	.525
2405	5.000	2.750	1.500	1.500	.250	2.000	.688	1.500	4.500	ø.328	ø.531	1.125	.750	.795

Recommended Mounting Hardware (Mount to T-Slot):

Part No.	Description	Base Plate	Quantity
3321	1/4-20 FBHSCS & Economy T-Nut	2414	2
		2416	4
		2404	6
3325	5/16-18 Economy T-Slot Stud w/Washer & Hex Nut	2415	2
		2417	4
		2405	6
OR			
3320	5/16-18 FBHSCS & Economy T-Nut	2415	2
		2417	4
		2405	6

496

We specialize in **FAST™** same day shipments!