











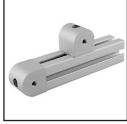

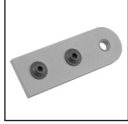



Section #5 Pictorial Table Of Contents

| | | | | | | |
|--|---|---|--|--|---|--|
| <p>How To Order</p>  <p>Page 816</p> | <p>Standard Living Hinge Assemblies</p>  <p>Pages 817-818</p> | <p>0° Living Nub</p>  <p>Page 819</p> | <p>90° Living Nub</p>  <p>Page 819</p> | <p>Universal Living Nub</p>  <p>Page 820</p> | <p>Straight Pivot Arm</p>  <p>Page 820</p> | <p>"L" Pivot Arm</p>  <p>Page 821</p> |
| <p>Right Angle Living Hinge Assemblies</p>  <p>Pages 822-823</p> | <p>0° Right Angle Living Nub</p>  <p>Page 824</p> | <p>90° Right Angle Living Nub</p>  <p>Page 824</p> | <p>Universal Right Angle Living Nub</p>  <p>Page 825</p> | <p>Straight Pivot Arm</p>  <p>Page 825</p> | <p>"L" Pivot Arm</p>  <p>Page 826</p> | <p>90° Pivot Brackets</p>  <p>Page 827</p> |
| <p>90° Pivot Bracket Assemblies</p>  <p>Page 828</p> | <p>180° Pivot Brackets</p>  <p>Page 829</p> | <p>180° Pivot Bracket Assemblies</p>  <p>Page 830</p> | | | | |

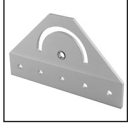

0° Living Hinge

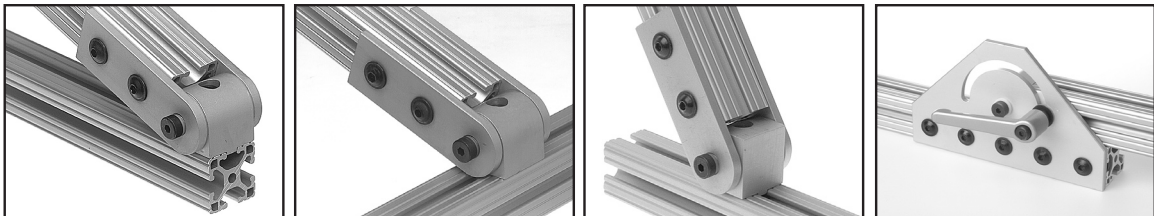
90° Living Hinge

Right Angle Living Hinge

180° Pivot Bracket

Legend for Icons



Design files for this part can be found on the 80/20® DVD (Design Software)



This part can use double economy T-nuts. See page 757.

How to Order 80/20® Dynamic Pivots

Dynamic pivots provide different methods of incorporating motion into specific areas of your application. Select a pivot according to the range and direction of motion required for the application (see example order below). Also take note of the recommended bolt assemblies called out for each specific Dynamic Pivot component. When you order something other than an assembly, a bolt kit will need to be specified. You may choose to select your own bolt configurations. If so, simply refer to pages 743-751 for bolt and T-nut options.

How To Order

Shipping Method: Ship To: Customer:
 Ordered By: Address:
 City / State:
 Attention:
 Tag:

Complete Address & Shipping Method Required... NO P.O. Box

| Part Number | Quantity | Length | Description / Machining | Price/UOM | Ext. Price |
|-----------------|----------|----------|---|-----------|------------------|
| 25-2525 | 2 | 469.9mm | 25-7042 in A both ends | \$0.01 | \$7.89 |
| 40-4040-Lite-4m | 5 | 4 m | Full length profile | \$80.00 | \$400.00 |
| 40-8016 | 4 | 1016.0mm | 40-7029 one end | \$0.14 | \$554.74 |
| 40-8080 | 4 | 914.4mm | 40-7050 style MG in W, X both ends | \$0.06 | \$230.43 |
| CM01-051006 | 2 | | Custom bracket per drawing #1 | \$23.00 | \$46.00 |
| 65-2611 | 1 | .63 sm | 6mm bronze polycarb 1 @ 457.2mm x 1016mm w/ 25-7311 per drawing | \$111.95 | \$70.53 |
| 65-7150 | 1 | | Cut plastic panels all sides < -1220mm | \$10.50 | \$10.50 |
| 25-7042 | 4 | | 25 Series anchor fastener counterbore | \$2.25 | \$9.00 |
| 25-7005 | 2 | | Cut-to-length for 25-2525 | \$1.95 | \$3.90 |
| 40-7023 | 4 | | Cut-to-length for 40-8016 | \$2.90 | \$11.60 |
| 40-7030 | 4 | | Cut-to-length for 40-8080 | \$2.60 | \$10.40 |
| 40-7050 | 64 | | 40 Series drill access hole | \$1.95 | \$124.80 |
| 40-7029 | 4 | | 5/16-18 tap service for 40-8016 | \$15.20 | \$60.80 |
| 25-7311 | 2 | | Anchor fastener notch for 25 Series | \$0.53 | \$1.06 |
| 40-3891 | 32 | | 40 Series M8 bright zinc end fastener w/ screw | \$1.65 | \$52.80 |
| 25-2114 | 16 | | Gray T-Slot covers for 25 Series | \$3.45 | \$55.20 |
| 40-2050 | 8 | | End caps for 40-8080 | \$1.85 | \$14.80 |
| 25-3896 | 4 | | 25 Series anchor fasteners | \$3.10 | \$12.40 |
| 40-1982 | 5 | | 40 Series M8 bright zinc double economy T-nut | \$0.84 | \$4.20 |
| 25-4132 | 12 | | 2 hole inside corner gusset bracket | \$3.95 | \$47.40 |
| 75-3404 | 24 | | 25 Series M6 BHSCS & economy T-nut | \$0.45 | \$10.80 |
| TOTAL | | | | | \$1739.25 |

NOTE: Prices shown for illustration use only. Contact your distributor for a personalized quote.

Special Instructions: **Must be delivered for assembly by Friday!!!**

1 - Profiles = Pages 640-694 • 2 - Custom Parts = Pages 695-710 • 3 - Panels = Pages 831-914
 4 - Machining Services = Pages 1025-1078 • 5 - Accessories & Tools = Pages 915-938 & 1015-1024

Living Hinge – 25 Series



- Permanently lubricated bronze bushings act as high strength pivot points
- Nylon thrust washers protect the pivot arms
- Offers a high load capacity while ensuring a long cycle life
- Provides a full 180° of axial motion

25 Series Mounting Hardware Included

Nub to Profile:
Part # 75-3415 – M6 x 25mm SHCS & Econ T-Nut

Nub to Arms:
Part # 25-3501 – (2) 8mm x 6mm Stripper Bolt & (4) Thrust Washers

Arm to Profile:
Part # 75-3509 – (2) M6 x 10mm BHSCS & Dbl Econ T-Nut
Part # 75-3541 – (2) M6 x 10mm FHSCS & Econ T-Nut

Individual Part No.

| 25-4181 | 25-4184 | 25-4177 | 25-4185 | 25-4172 |
|--------------------|---------------------|---------------------------|----------------------|---------------------|
| | | | | |
| 0° Nub Page 819 | 90° Nub Page 819 | Universal Nub Page 820 | 75mm Arm Page 820 | "L" Arm Page 821 |

| Assembly Part No. | 25-4180 | 25-4183 | 25-4178 | 25-4168 | 25-4169 | 25-4171 |
|-------------------|----------|----------|----------|----------|----------|----------|
| | | | | | | |
| | .105 kg. | .105 kg. | .150 kg. | .100 kg. | .100 kg. | .146 kg. |
| | 1 | 1 | 1 | 1 | 1 | 1 |
| | 2 | 2 | 2 | 2 | 2 | 2 |

Living Hinge – 40 Series









- Permanently lubricated bronze bushings act as high strength pivot points
- Nylon thrust washers protect the pivot arms
- Offers a high load capacity while ensuring a long cycle life
- Provides a full 180° of axial motion

40 Series Mounting Hardware Included

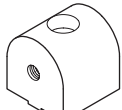
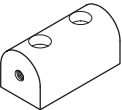
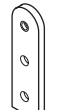
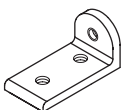
Nub to Profile:
Part # 75-3479 – M8 x 40mm SHCS & Econ T-Nut

Nub to Arms:
Part # 40-3500 – (2) 10mm x 10mm Stripper Bolt & (4) Thrust Washers

Arm to Profile:
Part # 75-3513 – (2) M8 x 16mm BHSCS & Dbl Econ T-Nut
Part # 75-3508 – (2) M8 x 16mm FHSCS & Econ T-Nut

| | | Individual Part No. | | | | |
|-------------------|----------------------------|---|--|--|--|--|
| | | 40-4381 | 40-4384 | 40-4377 | 40-4385 | 40-4343 |
| | |  0° Nub Page 819 |  90° Nub Page 819 |  Universal Nub Page 820 |  120mm Arm Page 820 |  "L" Arm Page 821 |
| Assembly Part No. | 40-4380 .327 kg. |  | 1 | | 2 | |
| | 40-4383 .327 kg. |  | | 1 | 2 | |
| | 40-4379 .474 kg. |  | | 1 | 2 | |
| | 40-4321 .322 kg. |  | 1 | | | 2 |
| | 40-4322 .322 kg. |  | | 1 | | 2 |
| | 40-4323 .469 kg. |  | | | 1 | 2 |

0° Living Nub

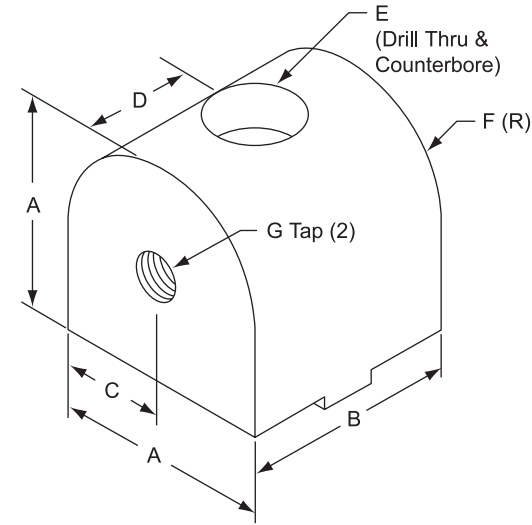

*One Bolt Assembly
Contains Qty 2 as Shown
Below

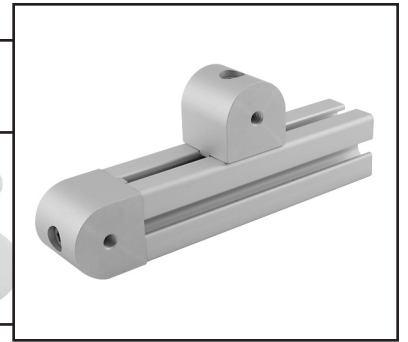
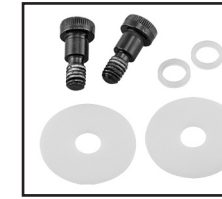

Included Mounting Hardware (Mount Nub to Profile):

| Series | Qty | Description |
|--------|-----|--------------------------------|
| 25 | 1 | M6 x 25mm SHCS & Economy T-Nut |
| 40 | 1 | M8 x 40mm SHCS & Economy T-Nut |

Recommended Pivot Bolt Assembly (Mount Nub to Arm):

| Part No. | Qty | Description |
|----------|-----|---|
| 25-3501 | 1* | 8mm x 6mm Stripper Bolts & Thrust Washers |
| 40-3500 | 1* | 10mm x 10mm Stripper Bolts & Thrust Washers |

| Part No. | A | B | C | D | E | F | G | kg. |
|----------|-------|-------|-------|-------|---------|-------|-----------|-------|
| 25-4181 | 25.00 | 23.73 | 12.50 | 11.85 | M6 SHCS | 12.50 | M6 X 1.00 | .0310 |
| 40-4381 | 40.00 | 38.70 | 20.00 | 19.35 | M8 SHCS | 20.00 | M8 X 1.25 | .1540 |

90° Living Nub

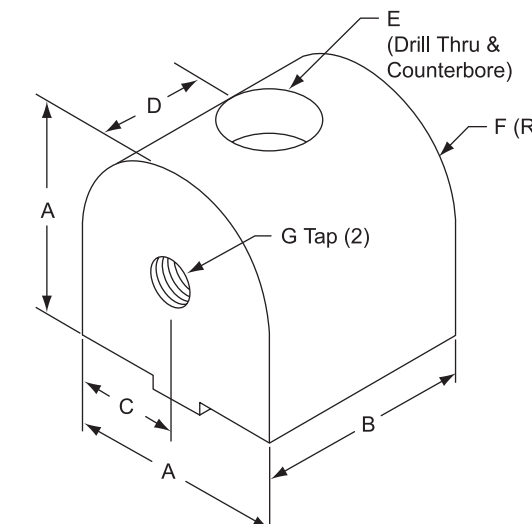

*One Bolt Assembly
Contains Qty 2 as Shown
Below

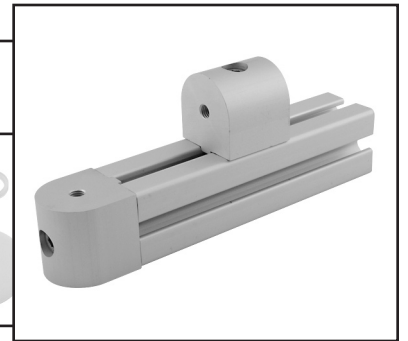
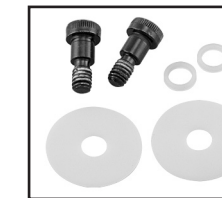

Included Mounting Hardware (Mount Nub to Profile):

| Series | Qty | Description |
|--------|-----|--------------------------------|
| 25 | 1 | M6 x 25mm SHCS & Economy T-Nut |
| 40 | 1 | M8 x 40mm SHCS & Economy T-Nut |

Recommended Pivot Mounting Hardware (Mount Nub to Arm):

| Part No. | Qty | Description |
|----------|-----|---|
| 25-3501 | 1* | 8mm x 6mm Stripper Bolts & Thrust Washers |
| 40-3500 | 1* | 10mm x 10mm Stripper Bolts & Thrust Washers |

| Part No. | A | B | C | D | E | F | G | kg. |
|----------|-------|-------|-------|-------|---------|-------|-----------|-------|
| 25-4184 | 25.00 | 23.73 | 12.50 | 11.85 | M6 SHCS | 12.50 | M6 X 1.00 | .0310 |
| 40-4384 | 40.00 | 38.70 | 20.00 | 19.35 | M8 SHCS | 20.00 | M8 X 1.25 | .1540 |

Universal Living Nub

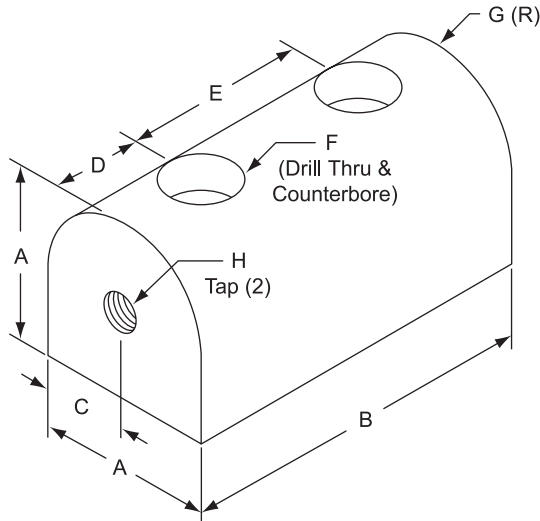

*One Bolt Assembly
Contains Qty 2 as Shown
Below

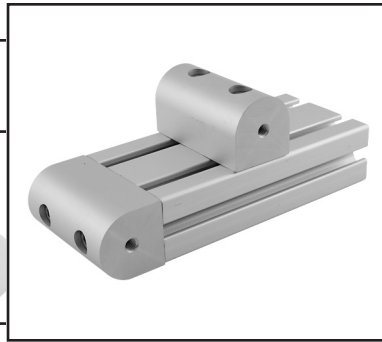

Included Mounting Hardware (Mount Nub to Profile):

| Series | Qty | Description |
|--------|-----|--------------------------------|
| 25 | 2 | M6 x 25mm SHCS & Economy T-Nut |
| 40 | 2 | M8 x 40mm SHCS & Economy T-Nut |

Recommended Pivot Mounting Hardware (Mount Nub to Arm):

| Part No. | Qty | Description |
|----------|-----|---|
| 25-3501 | 1* | 8mm x 6mm Stripper Bolts & Thrust Washers |
| 40-3500 | 1* | 10mm x 10mm Stripper Bolts & Thrust Washers |

| Part No. | A | B | C | D | E | F | G | H | kg. |
|----------|-------|-------|-------|-------|-------|---------|-------|-----------|-------|
| 25-4177 | 25.00 | 48.70 | 12.50 | 11.85 | 25.00 | M6 SHCS | 12.50 | M6 X 1.00 | .0640 |
| 40-4377 | 40.00 | 78.70 | 20.00 | 19.35 | 40.00 | M8 SHCS | 20.00 | M8 X 1.25 | .3090 |

"L" Pivot Arm



Page 757

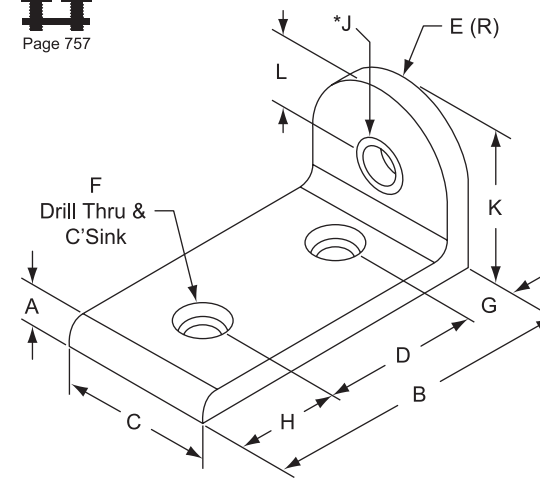

**One Bolt Assembly
Contains Qty 2 as Shown
Below

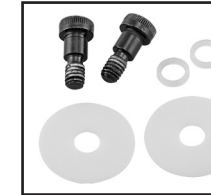

Included Mounting Hardware (Mount Arm to Profile):

| Series | Qty | Description |
|--------|-----|---------------------------------|
| 25 | 2 | M6 x 10mm FHSCS & Economy T-Nut |
| 40 | 2 | M8 x 16mm FHSCS & Economy T-Nut |

Recommended Pivot Mounting Hardware (Mount Pivot Arm to Nub):

| Part No. | Qty | Description |
|----------|-----|---|
| 25-3501 | 1** | 8mm x 6mm Stripper Bolts & Thrust Washers |
| 40-3500 | 1** | 10mm x 10mm Stripper Bolts & Thrust Washers |

* The internal diameter of the permanently lubricated bronze bushing.

| Part No. | A | B | C | D | E | F | G | H | J* | K | L | kg. |
|----------|------|-------|-------|-------|-------|----------|-------|-------|-------|-------|-------|-------|
| 25-4172 | 4.00 | 50.00 | 24.75 | 25.00 | 12.50 | M6 FHSCS | 12.50 | 12.50 | 8.00 | 25.00 | 12.50 | .0200 |
| 40-4343 | 6.00 | 80.00 | 39.80 | 40.00 | 19.90 | M8 FHSCS | 20.00 | 20.00 | 10.00 | 40.00 | 20.00 | .0690 |

Straight Pivot Arm



Page 757

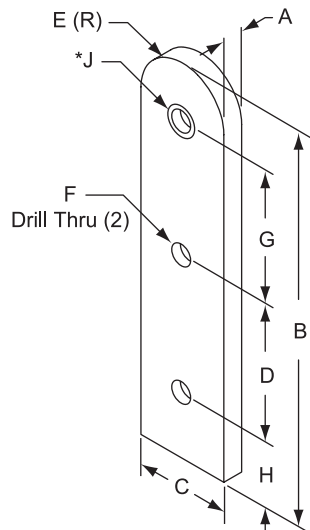

**One Bolt Assembly
Contains Qty 2 as Shown
Below

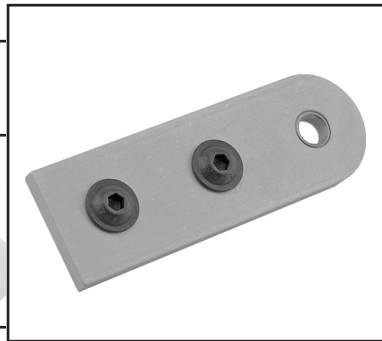

Included Mounting Hardware (Mount Arm to Profile):

| Series | Qty | Description |
|--------|-----|---------------------------------|
| 25 | 2 | M6 x 12mm BHSCS & Economy T-Nut |
| 40 | 2 | M8 x 16mm BHSCS & Economy T-Nut |

Recommended Pivot Mounting Hardware (Mount Pivot Arm to Nub):

| Part No. | Qty | Description |
|----------|-----|--|
| 25-3501 | 1** | M8 x 6mm Stripper Bolts & Thrust Washers |
| 40-3500 | 1** | M10 x 10mm Stripper Bolts & Thrust Washers |

* The internal diameter of the permanently lubricated bronze bushing.

| Part No. | A | B | C | D | E | F | G | H | J* | kg. |
|----------|------|--------|-------|-------|-------|-------|-------|-------|--------|-------|
| 25-4185 | 4.00 | 75.00 | 25.00 | 25.00 | 12.50 | ø6.30 | 25.00 | 12.50 | ø8.00 | .0220 |
| 40-4385 | 6.00 | 120.00 | 39.80 | 40.00 | 19.90 | ø8.30 | 40.00 | 20.00 | ø10.00 | .0710 |

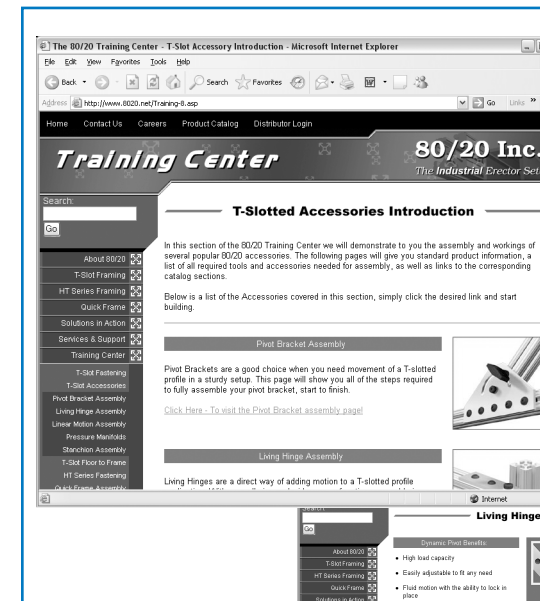

The 80/20[®] Training Center Offers Assembly Instruction Animations

Another feature of the 80/20 website is our online Training Center. This section of the site contains full motion assembly instructions for several standard 80/20 products.

Take a look at our fully illustrated assembly techniques for pivot nub and pivot bracket assemblies. You can even download this specific catalog section to your computer for quick reference.

Don't wait another second; visit our online Training Center at www.8020.net and see how 80/20 dynamic pivot solutions can go to work for you!

Right Angle Living Hinge – 25 Series



- Permanently lubricated bronze bushings act as high-strength pivot points
- Nylon thrust washers protect the pivot arms
- Offers a high load capacity while ensuring a long cycle life
- Provides a full 90° of axial motion







25 Series Mounting Hardware Included

Nub to Profile:
Part # 75-3415 – M6 x 25mm SHCS & Econ T-Nut

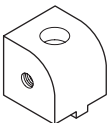
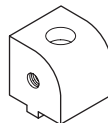
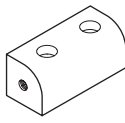
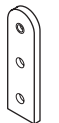
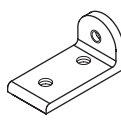
Nub to Arms:
Part # 25-3501 – (2) 8mm x 6mm Stripper Bolt & (4) Thrust Washers

Arm to Profile:
Part # 75-3509 – (2) M6 x 10mm BHSCS & Dbl Econ T-Nut
Part # 75-3541 – (2) M6 x 10mm FHSCS & Econ T-Nut

5

| | | Individual Part No. | | | | |
|-------------------|---------------------|---|--|--|---|--|
| | | 25-4025 | 25-4026 | 25-4027 | 25-4185 | 25-4172 |
| | |  0° Nub Page 824 |  90° Nub Page 824 |  Universal Nub Page 825 |  75mm Arm Page 825 |  "L" Arm Page 826 |
| Assembly Part No. | 25-4028 .107 kg. |  | 1 | | 2 | |
| | 25-4029 .107 kg. |  | | 1 | 2 | |
| | 25-4030 .152 kg. |  | | | 1 | 2 |
| | 25-4031 .104 kg. |  | 1 | | | 2 |
| | 25-4032 .104 kg. |  | | 1 | | 2 |
| | 25-4033 .147 kg. |  | | | 1 | 2 |

Right Angle Living Hinge – 40 Series



- Permanently lubricated bronze bushings act as high-strength pivot points
- Nylon thrust washers protect the pivot arms
- Offers a high load capacity while ensuring a long cycle life
- Provides a full 90° of axial motion







40 Series Mounting Hardware Included

Nub to Profile:
Part # 75-3479 – M8 x 40mm SHCS & Econ T-Nut

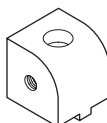
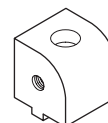
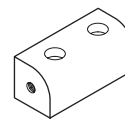
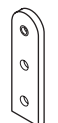
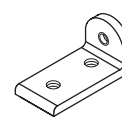
Nub to Arms:
Part # 40-3500 – (2) 10mm x 10mm Shoulder Bolt & (4) Thrust Washers

Arm to Profile:
Part # 75-3513 – (2) M8 x 16mm BHSCS & Dbl Econ T-Nut
Part # 75-3508 – (2) M8 x 16mm FHSCS & Econ T-Nut

5

| | | Individual Part No. | | | | |
|-------------------|---------------------|---|--|--|--|--|
| | | 40-4425 | 40-4426 | 40-4427 | 40-4385 | 40-4343 |
| | |  0° Nub Page 824 |  90° Nub Page 824 |  Universal Nub Page 825 |  120mm Arm Page 825 |  "L" Arm Page 826 |
| Assembly Part No. | 40-4428 .327 kg. |  | 1 | | 2 | |
| | 40-4429 .327 kg. |  | | 1 | 2 | |
| | 40-4430 .488 kg. |  | | | 1 | 2 |
| | 40-4431 .323 kg. |  | 1 | | | 2 |
| | 40-4432 .323 kg. |  | | 1 | | 2 |
| | 40-4433 .484 kg. |  | | | 1 | 2 |

0° Right Angle Living Nub

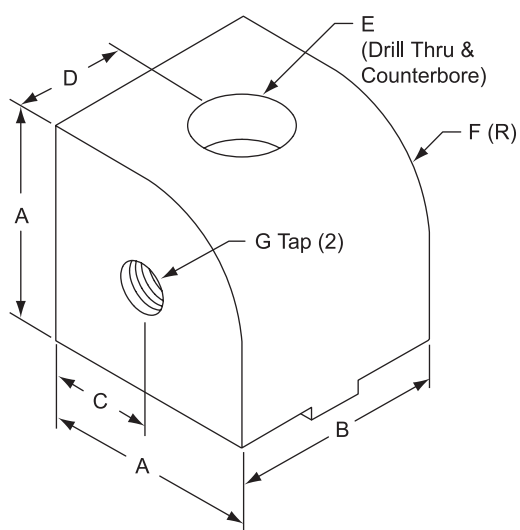

*One Bolt Assembly
Contains Qty 2 as Shown
Below

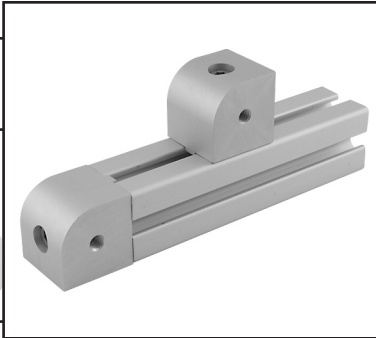
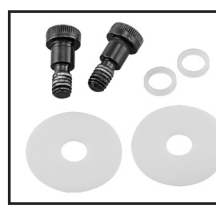

Included Mounting Hardware (Mount Nub to Profile):

| Series | Qty | Description |
|--------|-----|--------------------------------|
| 25 | 1 | M6 x 25mm SHCS & Economy T-Nut |
| 40 | 1 | M8 x 40mm SHCS & Economy T-Nut |

Recommended Pivot Mounting Hardware (Mount Nub to Arm):

| Part No. | Qty | Description |
|----------|-----|---|
| 25-3501 | 1* | 8mm x 6mm Stripper Bolts & Thrust Washers |
| 40-3500 | 1* | 10mm x 10mm Stripper Bolts & Thrust Washers |

| Part No. | A | B | C | D | E | F | G | kg. |
|----------|-------|-------|-------|-------|---------|-------|-----------|-------|
| 25-4025 | 25.00 | 23.70 | 12.50 | 11.85 | M6 SHCS | 12.50 | M6 X 1.00 | .0330 |
| 40-4425 | 40.00 | 38.70 | 20.00 | 19.35 | M8 SHCS | 20.00 | M8 X 1.25 | .1560 |

Universal Right Angle Living Nub

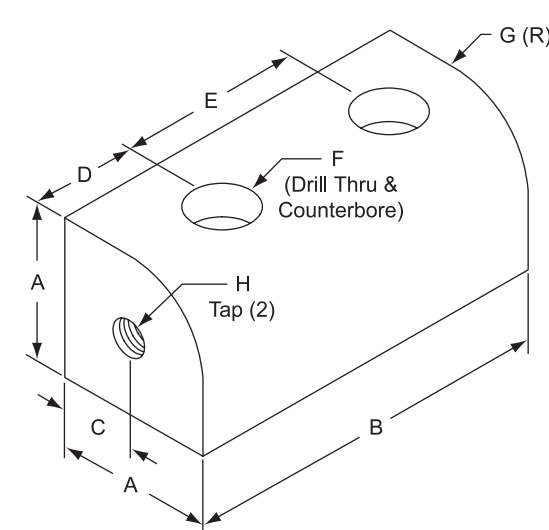

*One Bolt Assembly
Contains Qty 2 as Shown
Below

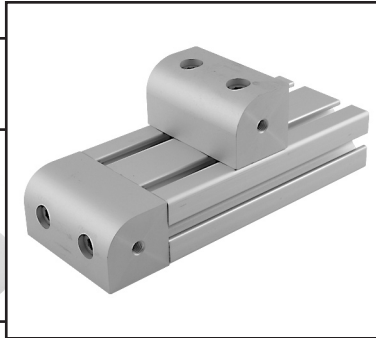
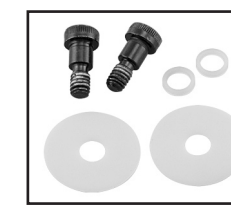

Included Mounting Hardware (Mount Nub to Profile):

| Series | Qty | Description |
|--------|-----|--------------------------------|
| 25 | 1 | M6 x 25mm SHCS & Economy T-Nut |
| 40 | 1 | M8 x 40mm SHCS & Economy T-Nut |

Recommended Pivot Mounting Hardware (Mount Nub to Arm):

| Part No. | Qty | Description |
|----------|-----|---|
| 25-3501 | 1* | 8mm x 6mm Stripper Bolts & Thrust Washers |
| 40-3500 | 1* | 10mm x 10mm Stripper Bolts & Thrust Washers |

| Part No. | A | B | C | D | E | F | G | H | kg. |
|----------|-------|-------|-------|-------|-------|---------|-------|-----------|-------|
| 25-4027 | 25.00 | 48.70 | 12.50 | 11.85 | 25.00 | M6 SHCS | 12.50 | M6 X 1.00 | .0640 |
| 40-4427 | 40.00 | 78.70 | 20.00 | 19.35 | 40.00 | M8 SHCS | 20.00 | M8 x 1.25 | .3110 |

90° Right Angle Living Nub

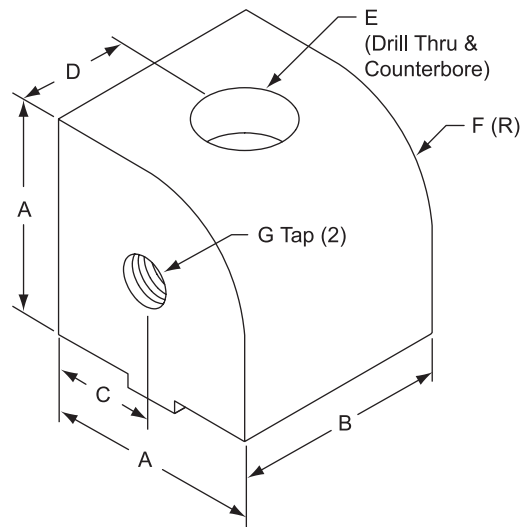

*One Bolt Assembly
Contains Qty 2 as Shown
Below

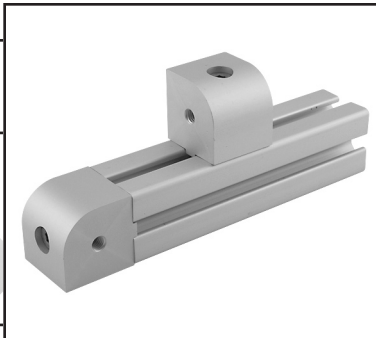
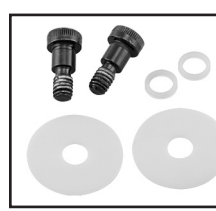

Included Mounting Hardware (Mount Nub to Profile):

| Series | Qty | Description |
|--------|-----|--------------------------------|
| 25 | 1 | M6 x 25mm SHCS & Economy T-Nut |
| 40 | 1 | M8 x 40mm SHCS & Economy T-Nut |

Recommended Pivot Mounting Hardware (Mount Nub to Arm):

| Part No. | Qty | Description |
|----------|-----|---|
| 25-3501 | 1* | 8mm x 6mm Stripper Bolts & Thrust Washers |
| 40-3500 | 1* | 10mm x 10mm Stripper Bolts & Thrust Washers |

| Part No. | A | B | C | D | E | F | G | kg. |
|----------|-------|-------|-------|-------|---------|-------|-----------|-------|
| 25-4026 | 25.00 | 23.70 | 12.50 | 11.85 | M6 SHCS | 12.50 | M6 X 1.00 | .0330 |
| 40-4426 | 40.00 | 38.70 | 20.00 | 19.35 | M8 SHCS | 20.00 | M8 X 1.25 | .1560 |

Straight Pivot Arm



Page 757

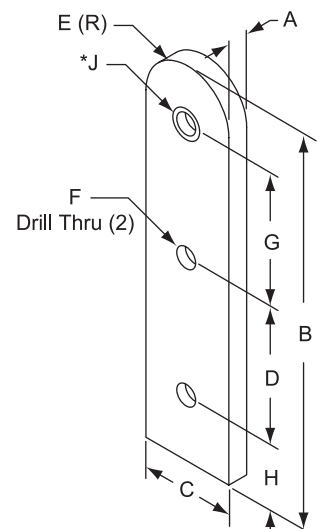

**One Bolt Assembly
Contains Qty 2 as
Shown Below

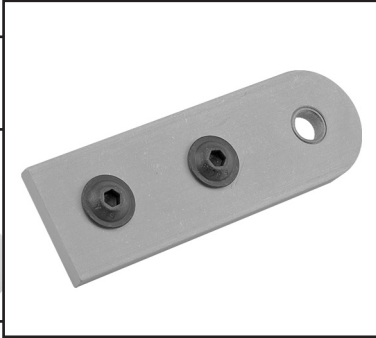
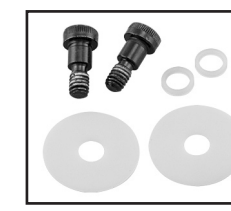

Included Mounting Hardware (Mount Arm to Profile):

| Series | Qty | Description |
|--------|-----|---------------------------------|
| 25 | 2 | M6 x 12mm BHSCS & Economy T-Nut |
| 40 | 2 | M8 x 16mm BHSCS & Economy T-Nut |

Recommended Pivot Mounting Hardware (Mount Pivot Arm to Nub):

| Part No. | Qty | Description |
|----------|-----|---|
| 25-3501 | 1** | 8mm x 6mm Stripper Bolts & Thrust Washers |
| 40-3500 | 1** | 10mm x 10mm Stripper Bolts & Thrust Washers |

* The internal diameter of the permanently lubricated bronze bushing.

| Part No. | A | B | C | D | E | F | G | H | J* | kg. |
|----------|------|--------|-------|-------|-------|-------|-------|-------|--------|-------|
| 25-4185 | 4.00 | 75.00 | 25.00 | 25.00 | 12.50 | ø6.30 | 25.00 | 12.50 | ø8.00 | .0220 |
| 40-4385 | 6.00 | 120.00 | 39.80 | 40.00 | 19.90 | ø8.30 | 40.00 | 20.00 | ø10.00 | .0710 |

"L" Pivot Arm

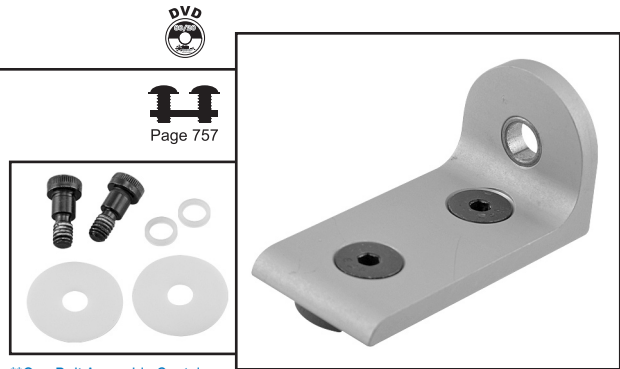

**One Bolt Assembly Contains Qty 2 as Shown

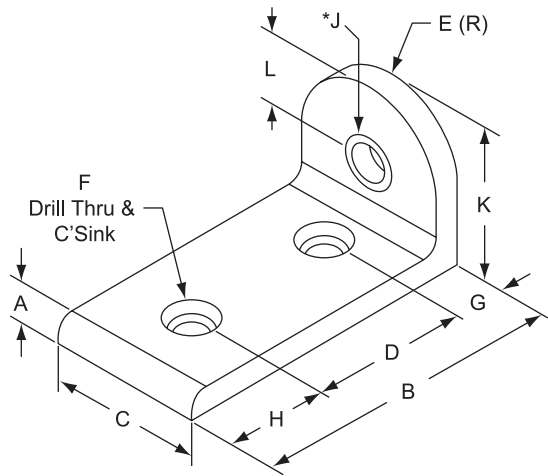

* The internal diameter of the permanently lubricated bronze bushing.

Included Mounting Hardware (Mount Arm to Profile):

| Series | Qty | Description |
|--------|-----|---------------------------------|
| 25 | 2 | M6 x 10mm FHSCS & Economy T-Nut |
| 40 | 2 | M8 x 16mm FHSCS & Economy T-Nut |

Recommended Pivot Mounting Hardware (Mount Pivot Arm to Nub):

| Part No. | Qty | Description |
|----------|-----|---|
| 25-3501 | 1** | 8mm x 6mm Stripper Bolts & Thrust Washers |
| 40-3500 | 1** | 10mm x 10mm Stripper Bolts & Thrust Washers |

| Part No. | A | B | C | D | E | F | G | H | J* | K | L | kg. |
|----------|------|-------|-------|-------|-------|----------|-------|-------|-------|-------|-------|-------|
| 25-4172 | 4.00 | 50.00 | 24.75 | 25.00 | 12.50 | M6 FHSCS | 12.50 | 12.50 | 8.00 | 25.00 | 12.50 | .0200 |
| 40-4343 | 6.00 | 80.00 | 39.80 | 40.00 | 19.90 | M8 FHSCS | 20.00 | 20.00 | 10.00 | 40.00 | 20.00 | .0690 |

90° Pivot Bracket



40-4337
Right Hand Shown

- Permanently lubricated bronze bushings act as high-strength pivot points
- Right and left hand versions are available, providing a full 90° of axial motion

Note: Right-Hand Version Shown

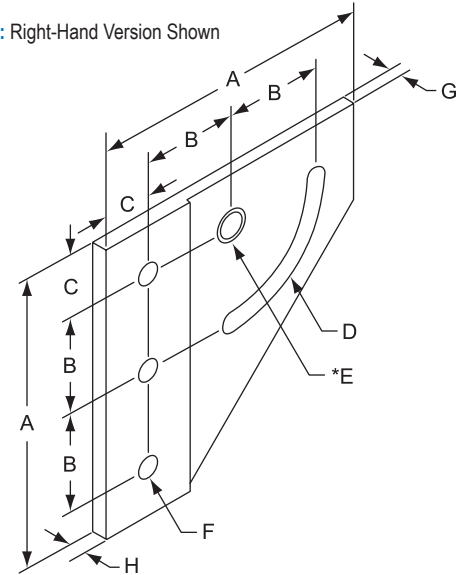

* The internal diameter of the permanently lubricated bronze bushing.

Recommended Mounting Hardware (Mount to Profile):

| Part No. | Qty | Description |
|----------|-----|---------------------------------|
| 75-3404 | 3 | M6 x 10mm BHSCS & Economy T-Nut |
| 75-3422 | 3 | M8 x 16mm BHSCS & Economy T-Nut |

| Part No. | Position | A | B | C | D | E* | F | G | H | kg. |
|----------|----------|--------|-------|-------|-------|--------|-------|------|------|-------|
| 25-4133 | Left | 75.00 | 25.00 | 12.50 | ø6.80 | ø8.00 | ø6.80 | 3.36 | 4.00 | .0480 |
| 25-4137 | Right | 75.00 | 25.00 | 12.50 | ø6.80 | ø8.00 | ø6.80 | 3.36 | 4.00 | .0480 |
| 40-4333 | Left | 120.00 | 40.00 | 20.00 | ø8.30 | ø10.00 | ø8.30 | 5.36 | 6.00 | .1550 |
| 40-4337 | Right | 120.00 | 40.00 | 20.00 | ø8.30 | ø10.00 | ø8.30 | 5.36 | 6.00 | .1550 |



Page 757

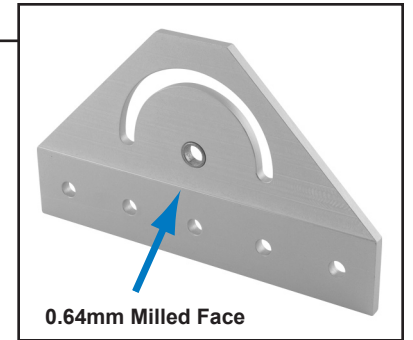

180° Pivot Bracket

- Permanently lubricated bronze bushings act as high-strength pivot points
- Right and left hand versions are available, providing a full 180° of axial motion

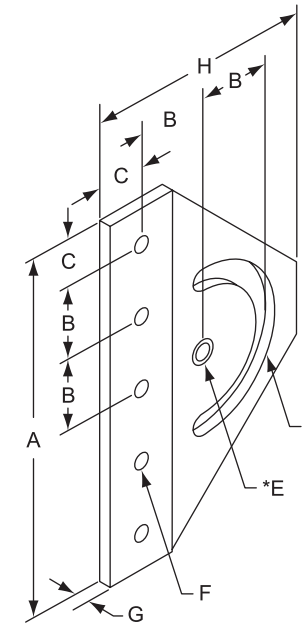

* The internal diameter of the permanently lubricated bronze bushing.















Recommended Mounting Hardware (Mount to Profile):

| Part No. | Series | Qty | Description |
|----------|--------|-----|---------------------------------|
| 75-3404 | 25 | 5 | M6 x 10mm BHSCS & Economy T-Nut |
| 75-3422 | 40 | 5 | M8 x 16mm BHSCS & Economy T-Nut |

| Part No. | A | B | C | D | E* | F | G | H | kg. |
|----------|--------|-------|-------|-------|--------|-------|------|--------|------|
| 25-4024 | 125.00 | 25.00 | 12.50 | ø6.80 | ø8.00 | ø6.80 | 4.00 | 75.00 | .069 |
| 40-4424 | 200.00 | 40.00 | 20.00 | ø8.30 | ø10.00 | ø8.30 | 6.00 | 120.00 | .245 |

| Assembly Part No. | Individual Part No. | | | | | | | | | |
|--------------------------|---------------------|----------------------|---------------------|----------------------|-----------|-----------|-----------|-----------|-----------|-----------|
| | 25-4133 | 25-4137 | 40-4333 | 40-4337 | 25-2796 | 40-2797 | 25-4187 | 25-4186 | 40-4387 | 40-4386 |
| | Left Hand 25 Series | Right Hand 25 Series | Left Hand 40 Series | Right Hand 40 Series | 25 Series | 40 Series | 25 Series | 25 Series | 40 Series | 40 Series |
| 25-4116 .209 kg. | 1 | 1 | | | 2 | | 1 | | | |
| 25-4124 .254 kg. | 1 | 1 | | | 2 | | 1 | | | |
| 25-4139 LH / .127 kg. | 1 | | | | 1 | | 1 | | | |
| 25-4148 RH / .127 kg. | | 1 | | | 1 | | 1 | | | |
| 40-4317 .786 kg. | | | 1 | 1 | | 2 | | | 1 | |
| 40-4318 .943 kg. | | | 1 | 1 | | 2 | | | | 1 |
| 40-4339 LH / .472 kg. | | | 1 | | | 1 | | | 1 | |
| 40-4348 RH / .472 kg. | | | | 1 | | 1 | | | 1 | |



| | | Individual Part No. | | | | | | | |
|-------------------|-----------------------------|--|--|--|--|--|---|--|--|
| | | 25-4024 | 40-4424 | 25-2796 | 40-2797 | 25-4187 | 25-4186 | 40-4387 | 40-4386 |
| | |  25 Series |  40 Series |  25 Series |  40 Series |  25 Series |  25 Series |  40 Series |  40 Series |
| Assembly Part No. | 25-4051 .154 kg. |  | 1 | 1 | | 1 | | | |
| | 25-4053 .259 kg. |  | 2 | 2 | | 1 | | | |
| | 25-4055 .309 kg. |  | 2 | 2 | | | 1 | | |
| | 40-4451 .553 kg. |  | | 1 | | 1 | | 1 | |
| | 40-4453 .957 kg. |  | | 2 | | 2 | | 1 | |
| | 40-4455 1.105 kg. |  | | 2 | | 2 | | | 1 |

5

- Milled .64mm washer clearance allows all structural members to be flush
- Assemblies include the structural nub, nylon washers, shoulder bolt, and “T” or “L” handle